

AIR DRIVEN LIQUID PUMPS

Hydraulics International, Inc.



InstruMetrics
ENGINEERING

CONTENTS

■ How the Pump Works, Advantages of the HII Pumps, How to Select Air Driven Pumps.....	2	■ Performance Curves	8, 9, 10, 11
■ Typical Applications.....	3	■ Compressibility of Water	11
■ Model Selection Table.....	4	■ Standard Modifications	12
■ Type of Materials in Contact with Fluid, Liquid Compatibility and Operating Temperature Limits	5	■ HII Power Units	13
■ Dimensional Data, Port Details	6, 7	■ Other HII Quality Products	14
		■ Hydraulics International, Inc. - Overview	15

HOW THE PUMP WORKS

Hydraulics International, Inc. (HII) air driven liquid pumps operate on the principle of differential working areas. An air piston drives a smaller diameter plunger or piston to provide a pressure ratio. The pressure ratio is the method of determining maximum outlet pressure available. Hydraulics International model numbers reflect the nominal pressure ratio of the pumps.

Hydraulics International liquid pumps operate at a drive air pressure of 12-150 psi (0.8-10 Bar) and will cycle automatically

when compressed air is first applied to the drive. It will start cycling at its maximum speed thus producing maximum fluid flow. At this stage, the pump is acting as a transfer pump, filling the pressure system with fluid. As resistance increases in the system (creating backpressure to the pump), the pump will decrease its reciprocating action. Backpressure in the system finally balances with the incoming air drive pressure times the ratio. At this point, the pump will stall and maintain pressure without consuming any energy. If there is further demand on the system for flow, the pump will automatically start cycling again.

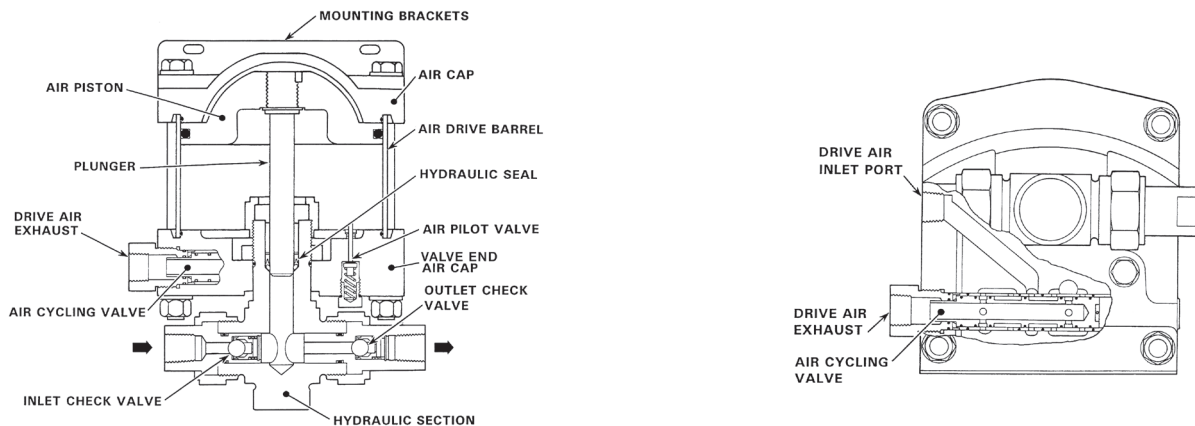

FIGURE 1. CROSS SECTION OF MODEL 5L-SS-RATIO

ADVANTAGES OF THE HII PUMPS

- Air Drive line lubrication not required.
- Self-priming for immediate operation.
- Compatible with all hydraulic fluids, plain water, distilled & deionized water, solvents, mild chemicals and most liquefied aerosol type gases.
- Stainless steel hydraulic body, check valves, and trim are standard, except -4 and -7 models.
- Hydraulic pressure is held without energy consumption.
- Explosion proof ... requires no electrical power or connections.
- Intrinsically safe.
- Compact, lightweight and weatherproof.
- Easy to adapt automatic controls.
- Alternative gases that can drive the pump include nitrogen, vapor from liquefied gas, pipeline natural gas and sour natural gas with proper modifications.
- Offer a wide range of standard modifications.
- Contamination tolerant.
- Outlet stall pressure pre-determined by the air drive regulator.
- High pressure capability - up to 80,000 psi (5516 Bar).
- Ideal for stop-start applications under full load.
- Easy to install and operate.
- ISO 9001: 2008 & AS9100-2009 Certified Quality System



HOW TO SELECT AIR DRIVEN PUMPS

There is a certain amount of information that has to be obtained from the customer in order to select an HII pump.

PARAMETERS FOR SELECTING A LIQUID PUMP

- Maximum discharge pressure, PSI (BAR)
- Flow rate at pressure, CU-IN/MIN (L/M)
- Drive air pressure available 12-150 PSI (0.8-10 BAR)
- Drive air quantity, SCFM (NM3/MIN)
- Type of fluid (water, oil, other)
- Working temperature, °F (°C)
- Application
- Operation - continuous or intermittent



TYPICAL APPLICATIONS

■ HYDROSTATIC TESTING:

Any component that is made to hold liquid or gas pressure needs to be carefully tested after manufacture or repair to verify its integrity, and/or to calibrate it. H.I.I. air driven pumps can simplify this requirement in a broad range of industries.

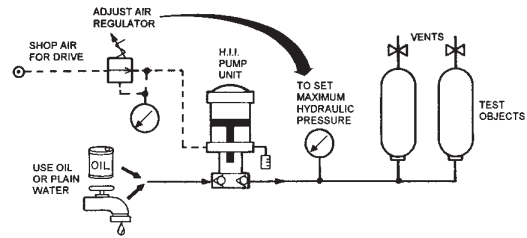

■ CLAMPING-PRESSING-RELEASING:

Hydraulic cylinders or rams that are required to maintain an output force without movement for long periods need a hydraulic pump that can maintain output pressure at zero flow for a long periods with no heat being generated. H.I.I. air driven pumps will do this over virtually any pressure range.

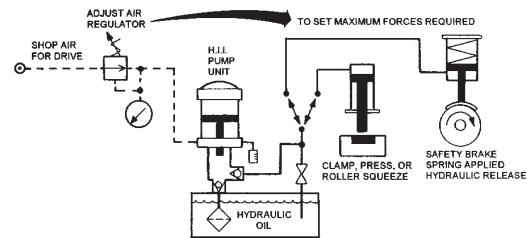

■ VALVE ACTUATION:

Pipeline gas is commonly used for bootstrap operation of pneumatic valve actuators. But where high force requirements meet low gas pressures, the size of the pneumatic actuator needed may be impractical. A gas driven H.I.I. pump with a small hydraulic actuator can often solve this at less cost.

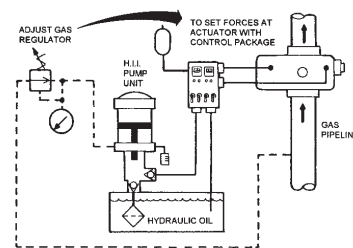

■ PORTABLE HYDRAULIC TOOLS:

To be easily handled on the job, these tools must be compact with minimum weight. This means hydraulic pressures beyond the reach of rotary hydraulic pumps ... but easily provided by H.I.I. air driven hydraulic pumps. For portability of the pump-tank package, the oil supply need be little more than the displacement of the tool it is teamed with because overheating can not occur.

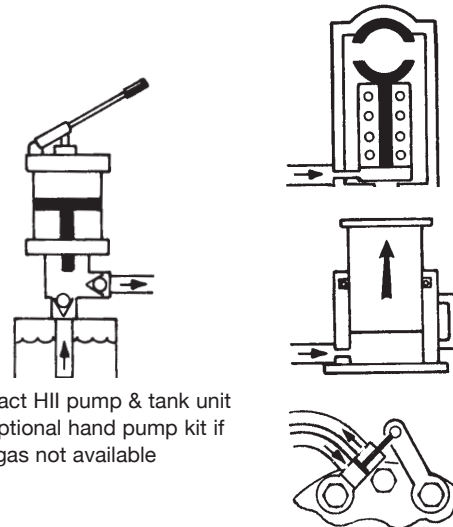

QUICK REFERENCE INTERNATIONAL EQUIVALENTS	
PRESSURE:	1 BAR = 14.5 PSI = 100 Kpa = 1.02 Kg/cm ² 1 Mpa = 10 BAR = 1000 Kpa
VOLUME:	1 LITRE = 61 IN ³ = .26 U.S. GALLON 1 NM ³ = 35.3 SCF
WEIGHT:	1 Kg = 2.2 LBS
LENGTH:	1 IN = 25.4 mm

MODEL SELECTION TABLE

Item #	Model with Ratio Dash Number ¹	Maximum Outlet Pressure ²		Volume Displacement Per Cycle		Liquid Port Detail ⁶	
		PSI	BAR	CU. IN.	M.L.	Inlet	Outlet
3" Single Acting, Single Air Drive							
1	3L-SS-8	1,200	83	0.82	13.4	3/4" NPT	1/2" NPT
2	3L-SS-14	1,950	134	0.46	7.5	3/4" NPT	1/2" NPT
3	3L-SS-25	3,750	259	0.25	4.1	3/8" NPT	1/4" NPT
4	3L-SS-41	6,150	424	0.15	3.3	3/8" NPT	1/4" NPT
5	3L-SS-81	12,150	838	0.08	1.3	3/8" NPT	1/4" NPT
6	3L-SS-125	15,000 ¹²	1,034	0.05	0.8	3/8" NPT	1/4" NPT
7	3L-SS-220	15,000 ¹²	1,034	0.03	0.5	3/8" NPT	1/4" SP ^{4,5}
5-3/4" Single Acting, Single Air Drive							
8	5L-SS-10	1,500	103	4.42	72.4	1" NPT	3/4" NPT
9	5L-SS-15	2,250	155	3.07	50.3	1" NPT	3/4" NPT
10	5L-SS-30	4,500	310	1.88	30.8	1/2" NPT	1/2" NPT
11	5L-SS-45	6,750	465	1.24	20.3	1/2" NPT	1/2" NPT
12	5L-SS-60	9,000	621	0.89	14.6	1/2" NPT	1/2" NPT
13	5L-SS-115	17,250	1,189	0.48	7.9	1/2" NPT	1/2" NPT
14	5L-SS-150	22,500	1,551	0.36	5.9	1/2" NPT	1/4" SP ^{4,5}
15	5L-SS-205	30,750	2,120	0.26	4.3	1/2" NPT	1/4" SP ^{4,5}
16	5L-SS-300	45,000	3,103	0.10	2.9	1/2" NPT	1/4" SP ^{4,5}
17	5L-SS-450	67,500	4,654	0.12	1.9	1/2" NPT	1/4" SP ^{4,5}
5-3/4" Single Acting, Double Air Drive							
18	5L-SD-20	3,000	207	4.42	72.4	1" NPT	3/4" NPT
19	5L-SD-30	4,500	310	3.07	50.3	1" NPT	3/4" NPT
20	5L-SD-60	9,000	621	1.88	30.8	1/2" NPT	1/2" NPT
21	5L-SD-90	13,500	931	1.24	20.3	1/2" NPT	1/2" NPT
22	5L-SD-120	18,000	1,241	0.89	14.6	1/2" NPT	1/2" NPT
23	5L-SD-230	34,500	2,379	0.48	7.9	1/2" NPT	1/4" SP ^{4,5}
24	5L-SD-300	45,000	3,103	0.36	5.9	1/2" NPT	1/4" SP ^{4,5}
25	5L-SD-410	61,500	4,240	0.26	4.3	1/2" NPT	1/4" SP ^{4,5}
26	5L-SD-600	80,000	5,516	0.18	2.9	1/2" NPT	1/4" SP ^{4,5}
5-3/4" Single Acting, Triple Air Drive							
27	5L-ST-900	80,000	5,516	0.18	2.9	1/2" NPT	1/4" SP ^{4,5}
5-3/4" Double Acting³, Single Air Drive							
28	5L-DS-4	1,250	86	24.1	394.9	-10 SAE ⁶	-10 SAE ⁵
5-3/4" Double Acting³, Double Air Drive							
29	5L-DD-20	3,000	207	8.84	144.9	1" FNPT	3/4" FNPT
30	5L-DD-30	4,500	310	6.14	100.6	1/2" FNPT	1/2" FNPT
31	5L-DD-60	9,000	621	3.76	61.6	1/2" FNPT	1/2" FNPT
32	5L-DD-90	13,500	931	2.48	40.6	1/2" FNPT	1/2" FNPT
33	5L-DD-120	18,000	1,241	1.78	23.2	1/2" FNPT	1/2" FNPT
34	5L-DD-230	34,500	2,379	0.96	15.7	1/2" FNPT	1/4" SP
35	5L-DD-300	45,000	3,103	0.72	11.8	1/2" FNPT	1/4" SP
36	5L-DD-410	61,500	4,240	0.52	8.5	1/2" FNPT	1/4" SP
37	5L-DD-600	80,500	5,516	0.36	5.9	1/2" FNPT	1/4" SP
7" Double Acting³, Single Air Drive							
38	7L-DS-7	1,250	86	41.4	678.4	-10 SAE ⁶	-10 SAE ⁵
39	7L-DS-35	5,250	362	7.8	127.8	1-1/4" NPT	1/2" NPT
40	7L-DS-60	9,000	621	4.7	77.0	1-1/4" NPT	1/2" NPT
41	7L-DS-100	15,000	1,034	2.8	45.9	1-1/4" NPT	1/2" NPT
7" Double Acting³, Double Air Drive							
42	7L-DD-70	10,500	724	7.8	127.8	1-1/4" NPT	1/2" NPT
43	7L-DD-120	18,000	1,241	4.7	77.0	1-1/4" NPT	9/16" MP ^{4,5}
44	7L-DD-200	20,000 ¹²	1,379	2.8	45.9	1-1/4" NPT	9/16" MP ^{4,5}

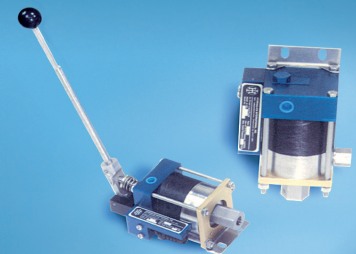

WEIGHT: 7-9 LBS.



WEIGHT: 24-27 LBS.

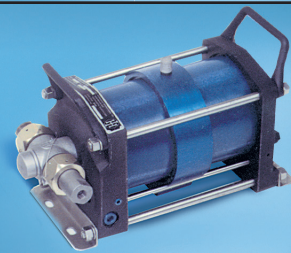

WEIGHT: 29-32 LBS.



WEIGHT: 34 LBS.



WEIGHT: 30 LBS.



WEIGHT: 35 LBS.

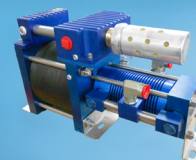

WEIGHT: 45-50 LBS.

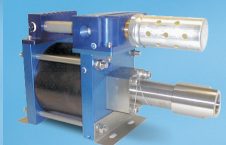

WEIGHT: 50-54 LBS.

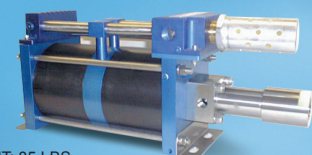

WEIGHT: 85 LBS.

TYPE OF MATERIALS IN CONTACT WITH FLUID

Series	Hydraulic Body	Hydraulic Plunger	Check Valves		Static O-Rings	Plunger Seal
			Inlet	Outlet		
3L						
-8 thru -81	316SS	316 SS	316 SS	316 SS	BUNA-N	UHMWPE ⁷
-125 thru -220	15-5 PH	316 SS	316 SS	316 SS	BUNA-N	UHMWPE
5L						
-10 thru -230	15-5 PH	15-5 PH	15-5 PH	15-5 PH	BUNA-N	UHMWPE
-300 thru -900	15-5 PH	STELLITE	15-5 PH	15-5 PH	BUNA-N	UHMWPE
-4	ALUMINUM	15-5 PH (Rod & Piston)	316 SS	316 SS	BUNA-N	Compounded PTFE (Rod & Piston)
7L						
-7	ALUMINUM	15-5 PH (Rod & Piston)	316 SS	316 SS	BUNA-N	Compounded PTFE
-35 thru -200	15-5 PH		15-5 PH			UHMWPE (Rod & Piston)

LIQUID COMPATIBILITY:	SERIES		
	3L	5L	7L
Hydraulic Fluid - Petroleum, Water, or Veg. Oil Based	Yes	Yes	Yes
Hydraulic Fluid - Skydrol or Brake Fluids	Yes ⁸	Yes ⁸	Yes ⁸
Water - Plain, Distilled, Deionized	Yes	Yes	Yes
Solvents Compatible with BUNA-N	Yes	Yes	Yes
Liquified Gases ⁹	Yes	Yes	No ⁹
SUCTION PRESSURES ¹¹	Up to maximum outlet pressure		Limit to approx. 30 PSI. Except 7L-DS-7: Approx 500 PSI.
TEMPERATURE LIMITATIONS:	+10°F to +150°F. "V" Modification (pg. 12) can increase limit to about 200°F		
Drive Sections ¹⁰			
Liquid Sections	+180°F Maximum. If higher, contact factory.		

NOTES (REFERENCE PAGE 4 & 5):

- Dash No. is Nominal area ratio of drive vs. liquid section. Actual area ratio is approximately 15% higher. E.g. item 1, Nominal area ratio is -8 and actual area ratio is -9
- Maximum rated outlet pressure of the pump with 150-psi drive (10 Bar)
- Items 28-38 use liquid inlet pressure to assist the force of the drive. E.g. item 28, if liquid inlet pressure is 200-psi; drive air pressure 100-psi; stall pressure will be approximately 200+400=600-psi. These pumps take in and discharge ½ of its displacement with either direction of stroke. Item 39-44 take in full displacement on their suction stroke, while discharging ½ that volume. Then on the opposite stroke, the other ½ of the volume is discharged to complete one cycle
- ¼" SP fits supper pressure threaded and coned ¼" OD tube. 9/16" MP fits medium pressure threaded and coned 9/16" OD tube
- Reference Table 1 on page 7 for port details
- Reference Table 2 on page 7 for air drive port details
- Ultra-High-Molecular-Weight Polyethylene
- Requires "D" and "E" modifications (pg 12). Note: For most other industrial phosphate ester fluids if drive receives "V" modification, "D" and "E" modifications not required.
- Ref. HII technical bulletin TB101. Model 7L-DS-7 is suitable for liquified gases.
- Pneumatic motors and drives of all types severely cool their drive air or gas while performing work. Unless the drive air is heated and the dew point is well below 32° F, there is potential for ice to form in the drive resulting in slow down or stopping. This probably indicates a common misapplication: running the pump under load for a sustained period. For suggestions on how this can be avoided, contact factory.
- Although all models will self-prime when tank-top mounted with most fluids, a flooded suction is recommended for models -200 thru -900, all series. For models 5L-SS-450, -SD-600, -ST-900 in heavy duty hydrostatic testing or isostatic press applications, a supercharge pump such as model 3L-SS-41 is recommended to extend fatigue life. The supercharge pump should also be protected from reverse leakage with a relief valve set at 10% above its stall pressure.
- Maximum rated outlet pressure for stainless steel configuration under continuous operation.
Intermittent operation:
Item 6 - 18,750 PSI (1,293 BAR) max outlet
Item 7 - 21,000 PSI (1,448 BAR) max outlet
Item 44 - 20,000 PSI (1,379 BAR) max outlet

DIMENSIONAL DATA

3L-SS -25 THRU -220

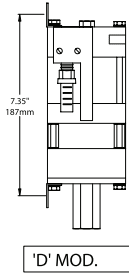
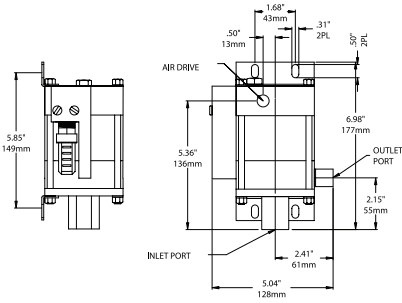

3L-SS -8, -14

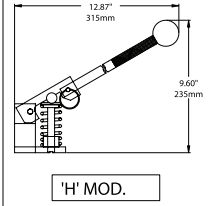
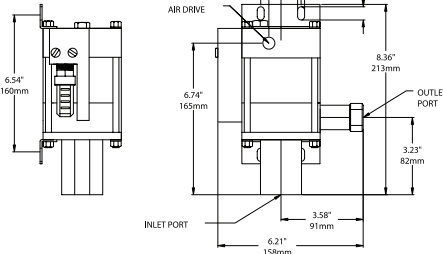

5L-DS -4

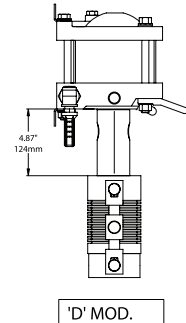
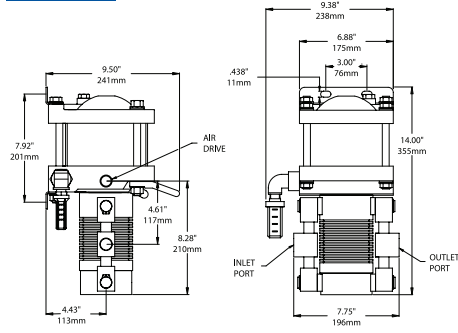

5L-SS -10, -15

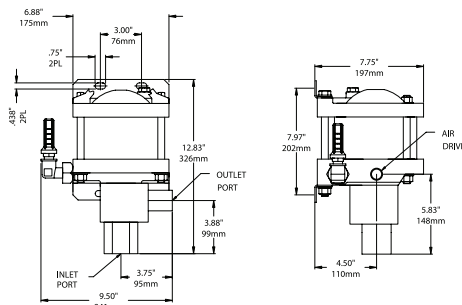

5L-SD -20, -30

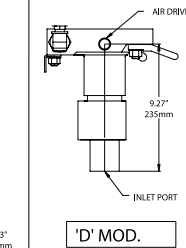
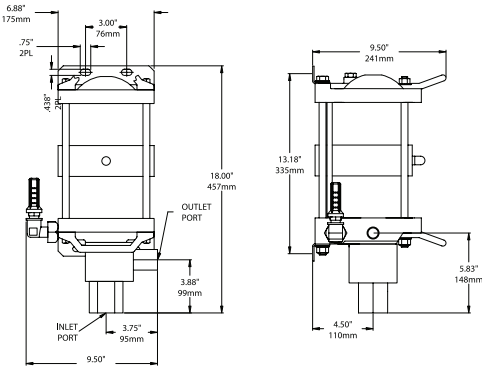

5L-SS -30 THRU -450

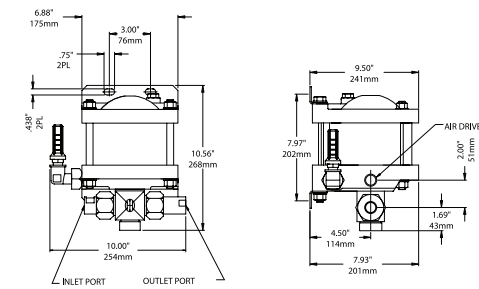

5L-SD -60 THRU -600 & 5L-ST -900

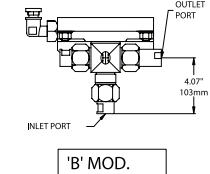
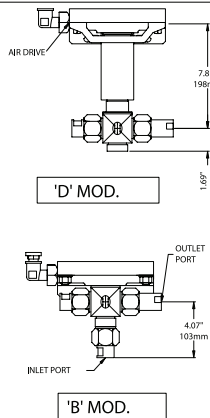
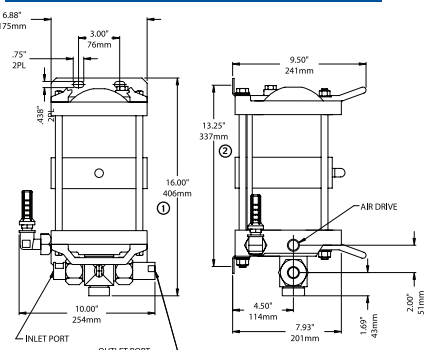

5L-DD -20, -30

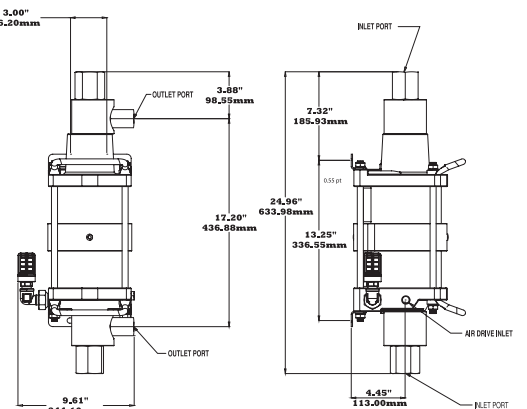

5L-ST -900 ONLY ① 21.34" ② 18.60"
All other dimensions remain as illustrated.

DIMENSIONAL DATA

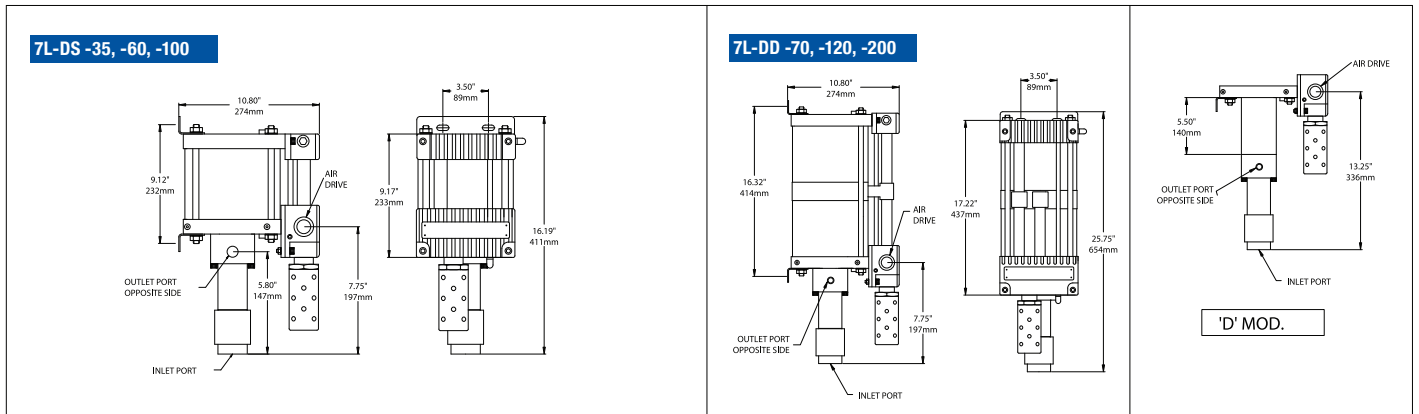
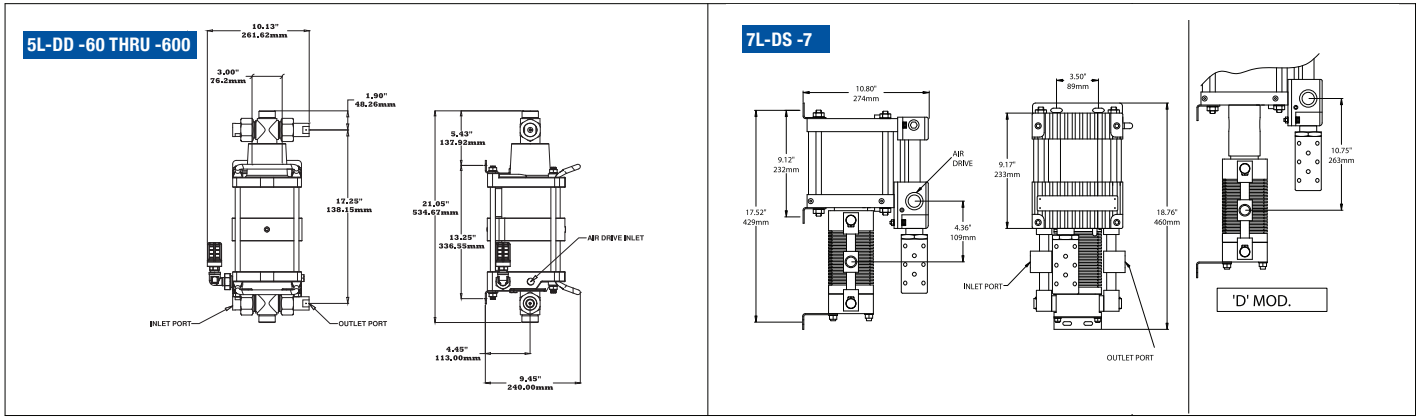

TABLE 1. PORT DETAILS

Port	Thread, Inches
-4 SAE	7/16-20
-8 SAE	3/4-16
-10 SAE	7/8-14
1/4" SP	9/16-18
9/16" MP	13/16-16

Model Designation System: 1 - 2 3 - 4 - 5

Example: 5L-SD-300-X

Box 1: Pump Series: 3L, 5L, or 7L.

Box 2: Pump Action: S-Single Acting, D-Double Acting

Box 3: Drive Piston(s): S-Single piston, D-Two Pistons, T- Three Pistons

Box 4: Nominal Area Ratio-Drive vs Pump Section

Box 5: Modification (See Page 12)

TABLE 2. AIR PORT DETAILS

Series	Air Drive	Pilot	Exhaust
3L	1/4" NPT	1/8" NPT	1/4" NPT
5L	-8 SAE	-4 SAE	1/2" NPT
7L	3/4" NPT	1/8" NPT	1 1/4" NPT

WE OFFER: ▶▶▶ Technical Advise
▶▶▶ Toll-Free Number: 888-780-PUMP (7867)
▶▶▶ After Sales Service

PERFORMANCE CURVES

These curves predict the performance of each model using **drive pressures** shown 150/95/75/50-psi, 10/7/5/3-Bar (interpolate for other pressures). Maximum flow points presume 1/4" I.D. drive line minimum to 3L Series; 1/2" I.D. minimum to 5L Series; And 3/4" I.D. minimum to 7L Series. Note: Limited drive flow does not inhibit maximum outlet pressure capacity.

AIR DRIVE FLOW (DOTTED CURVES)

3L-SERIES	A	B	C	
	6 SCFM 0.17 M ³ /M	12 SCFM 0.34 M ³ /M	18 SCFM 0.51 M ³ /M	
5L-SERIES	A	B	C	D
	15 SCFM 0.42 M ³ /M	30 SCFM 0.85 M ³ /M	60 SCFM 1.7 M ³ /M	75 SCFM 2.12 M ³ /M

NOTES:

1 Shaded area exceeds rated pressure. For intermittent use in this area, consult factory.

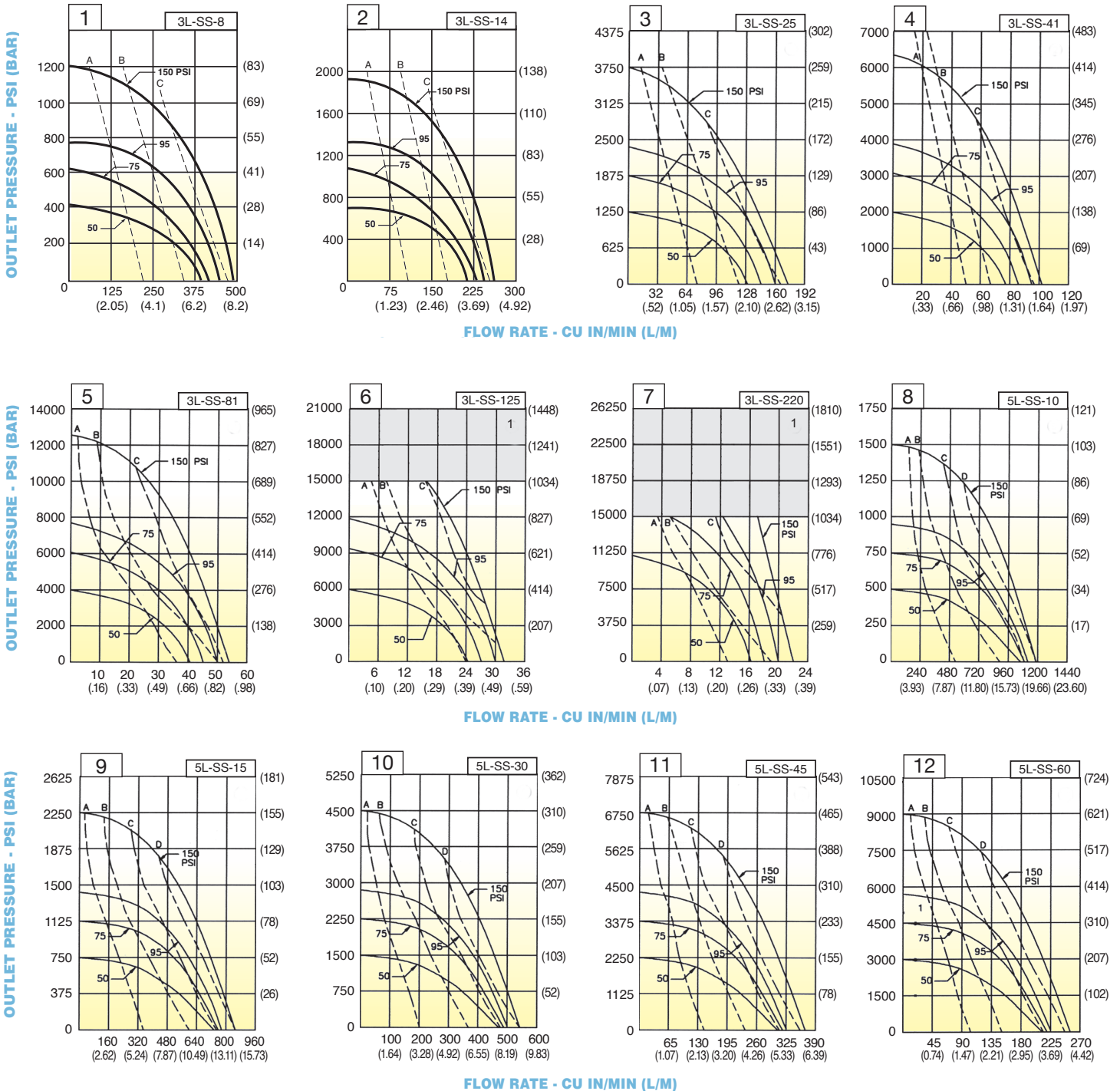
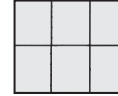

PERFORMANCE CURVES

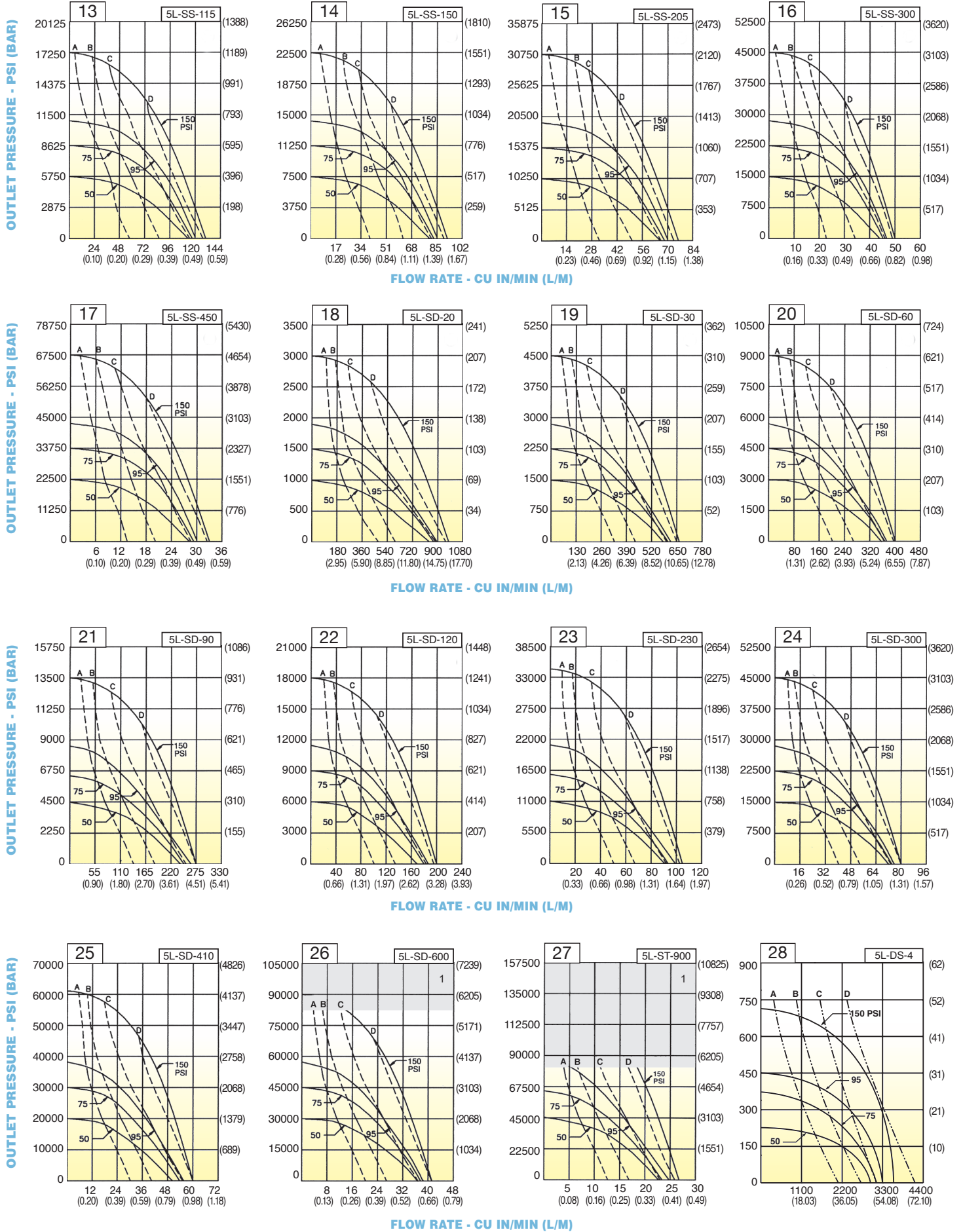

PERFORMANCE CURVES

OUTLET PRESSURE - PSI (BAR)

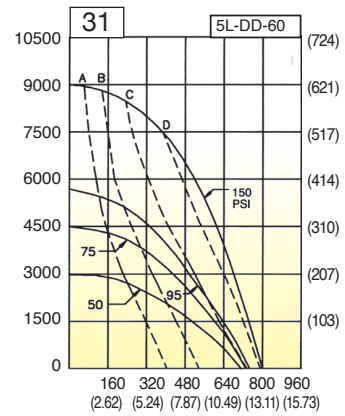
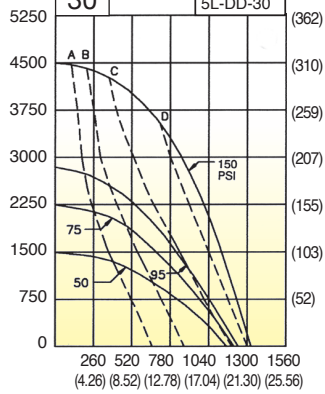
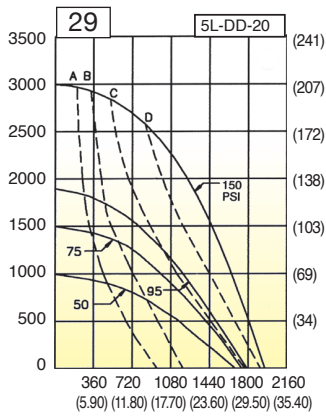

FLOW RATE - CU IN/MIN (L/M)

OUTLET PRESSURE - PSI (BAR)

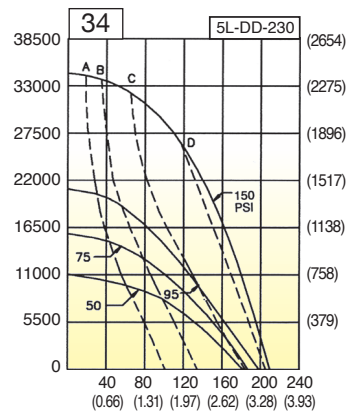
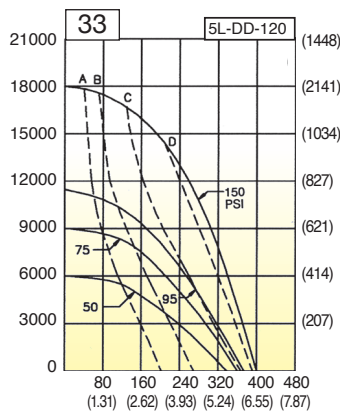
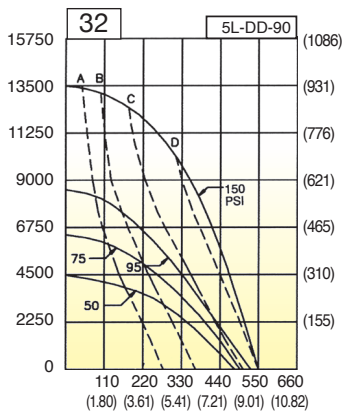

FLOW RATE - CU IN/MIN (L/M)

OUTLET PRESSURE - PSI (BAR)

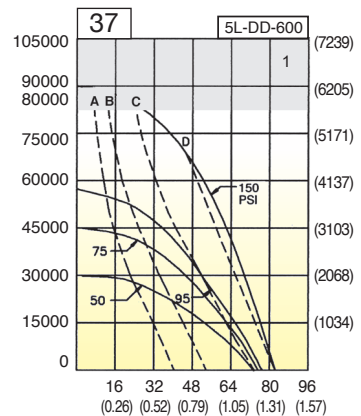
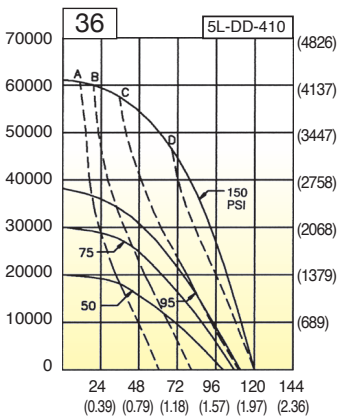
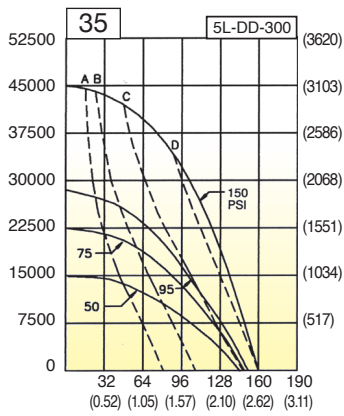

FLOW RATE - CU IN/MIN (L/M)

AIR DRIVE FLOW (DOTTED CURVES)

5L-SERIES	A	B	C	D
	15 SCFM	30 SCFM	60 SCFM	75 SCFM
	0.42 M ³ /M	0.85 M ³ /M	1.7 M ³ /M	2.12 M ³ /M

NOTES:

1 Shaded area exceeds rated pressure. For intermittent use in this area, consult factory.

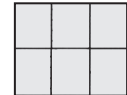

PERFORMANCE CURVES

AIR DRIVE FLOW (DOTTED CURVES)

7L-SERIES	A	B	C	D
	45 SCFM	85 SCFM	120 SCFM	165 SCFM
	1.27 M ³ /M	2.4 M ³ /M	3.4 M ³ /M	4.67 M ³ /M

NOTES:

1 Shaded area exceeds rated pressure. For intermittent use in this area, consult factory.

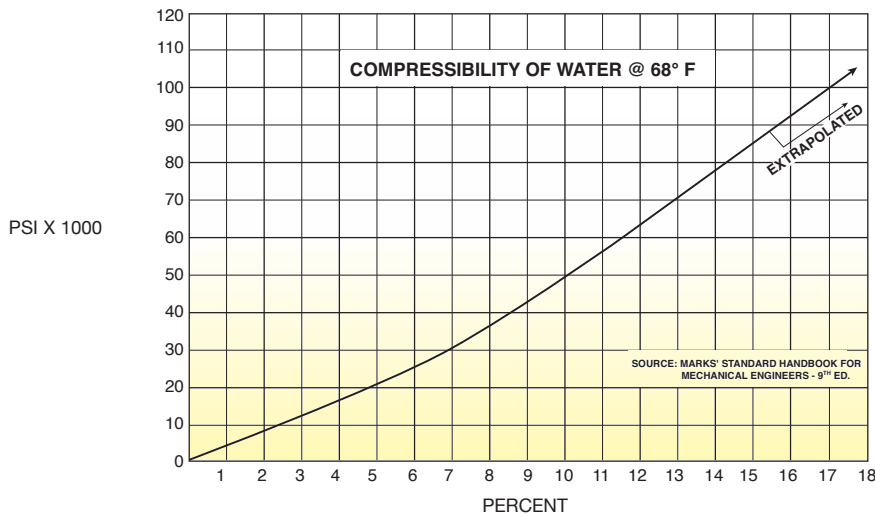
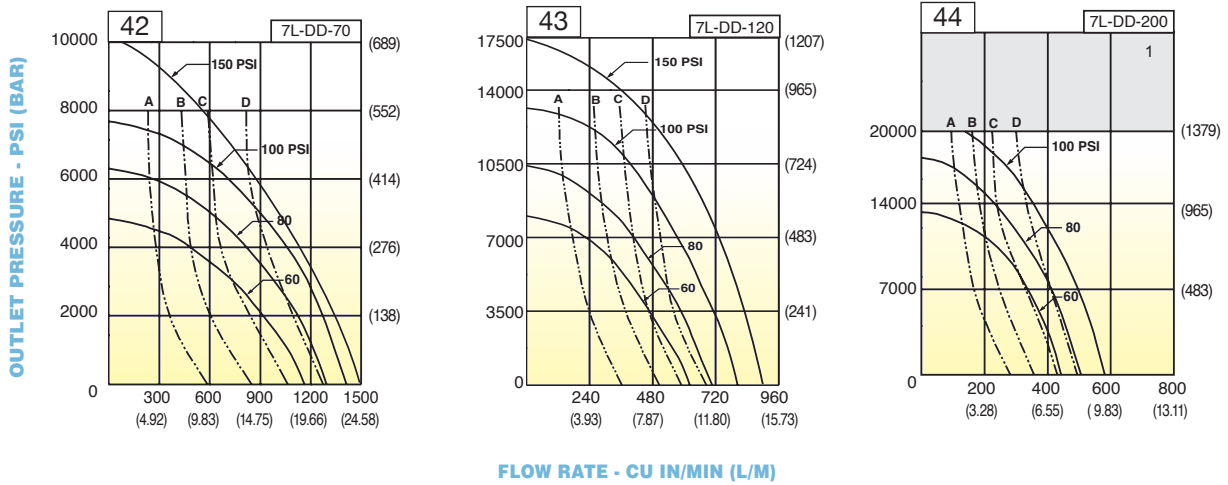
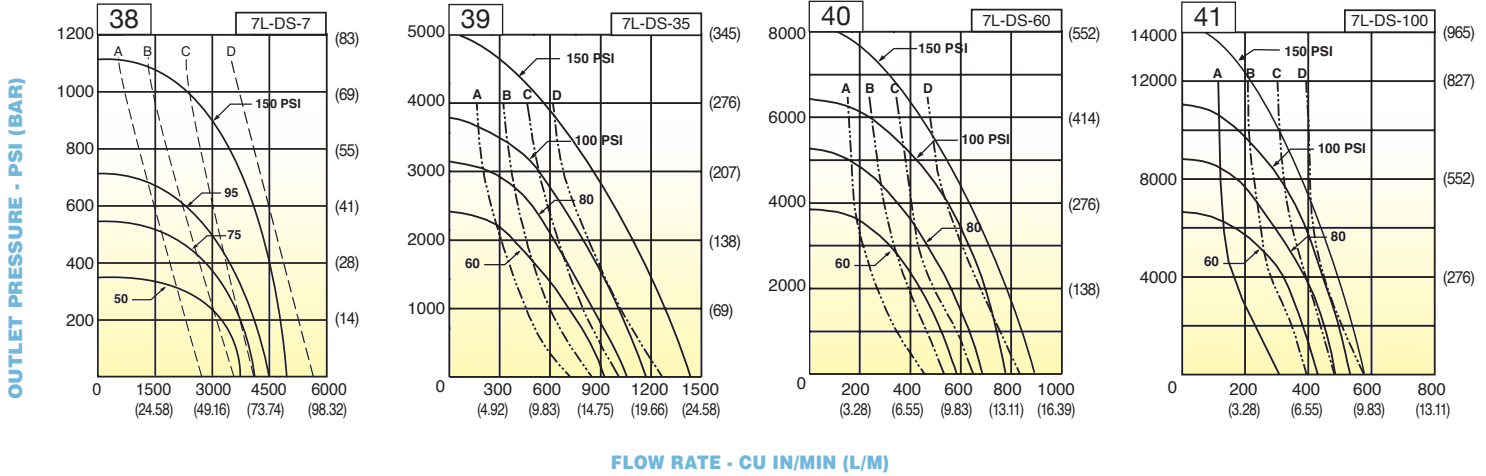
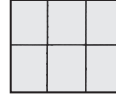

STANDARD MODIFICATIONS

- **“B” Bottom Inlet.** See dimensional data pg.6 and selection table pg. 4. This modification applies only to model item numbers 10 through 17 and 20 through 27. It is not available for item 28 or 29. It is standard on items 1-9, 18, 19, and 30-35 (which are not available with side inlet).
- **“D” Distance Piece.** All series. Provides vented, dual seal protection where leakage or fumes from pumped fluid could attack the air drive section with only the single seal. Specify by adding -“D” after model number, e.g. Model 5L-SS-30-D. Double distance piece also available to protect air drive from some high or low temperature liquids. Specify by adding -“DD” after model number (5L Series only).
- **“E” EPR (Ethylene Propylene) Static Seals in Liquid Section Only.** All series. Replaces all Buna static seals. Provides needed chemical resistance if liquid section is used with liquids incompatible with Buna, such as Skydrol. Standard Ultra High Molecular Weight Polyethylene plunger seal is not changed. It is compatible with Skydrol. Specify by adding -“E” after model number, e.g. Model 5L-SS-30-E. Note: -“D” Modification also highly recommended to protect air drive seals.
- **“H” Hand Pump Attachment.** 3L Series only. Permits supplementary operation of the pump by hand. Useful in precise testing or emergency backup applications requiring a hand pump in addition to a power pump. Specify by adding “H” after model number, e.g. Model 3L-SS-41-H.
- **“L” Low Air Drive Pressure.** 5L Series only. Allows operation of the pump with an air drive pressure regulated as low as 2-3 psi. Also includes “X” modification. External pilot pressure must be 30 psi or more. Specify by adding -“L” after model number, e.g. Model 5L-SS-30-L.
- **“P” Piped Exhaust.** All series. Enables complete capture of exhaust air or gas from both the drive and pilot exhaust ports. Permits submerged operation inside hydraulic tanks, and/or piping exhausting gases out of the area for safety considerations. Exhaust ports for drive and pilot are 1/4” NPT and 1/8” NPT respectively on the 3L and 1-1/4” & 1/8” NPT on the 7L Series. On the 5L Series, drive and pilot exhaust are joined at a 1/2” NPT outlet. Specify by adding -“P” after the model number, e.g. 5L-SS-30-P.
- **“S” Single Stroke.** 5L Series and 3L series except -4. Useful for testing, metering or single stroke intensifier type hydraulic applications. Pump cycles once when momentary air pulse is applied to 1/8” NPT “S” port. Pump will not cycle otherwise. Specify by adding “S” after model number, e.g. Model 5L-SS-30-S.
- **“RC” Retract Command.** 5L Series only except -4. Similar to “S”. Momentary air pulse will put pump on retract stroke; otherwise pump cycles normally. Used for close control of test pressures. Precision air regulator recommended.
- **“V” Viton Sealed Drive Section.** 3L, 5L and 7L Series. Replaces all Buna static and dynamic seals. Provides needed chemical resistance if drive air or gas has entrained substances incompatible with Buna, such as hydrogen sulfide or some synthetic lubricants sometimes found in plant air compressors. Specify by adding -“V” after model number, e.g. Model 5L-SS-30-V.
- **“V1” Viton Static O-rings in Liquid Section.** For higher temperatures than advisable for Buna, and for extra resistance to some chemicals. Specify by adding “V1” after model number.
- **“X” External Pilot Port on the Drive Section.** All series. Enables start-stop control of drive with small shutoff valve. 3L, 7L Series 1/8” NPT, 5L Series -4 SAE (7/16”)-20 threads). Specify by adding -“X” after model number, e.g. Model 5L-SS-30-X.
- **“R” Remove Return Spring in Drive Section.** 3L Series only. For use with pressurized suction applications such as liquified gases. Improves filling action in the pump body on the suction stroke. Usually limited to -8 thru -41 ratios.
- **“T” 3 Way Cycling Spool in Drive.** 5L Series only. For use with pressurized suction applications (As described for “R” Mod above).

HII POWER UNITS:

Hydraulics International, Inc. (HII) offers a wide range of hydraulic power units suited for operation in mobile, defense, petrochemical, offshore and industrial applications. Standard compact and custom power units are available where an immediate pressure test is on demand. These hydraulic power units are self-contained; plug and play ready to operate only requiring connection to a shop air compressor and test device.

Standard power units type HIHPT4 includes the following items:

- Air controls (regulator, filter, pressure gauge and on/off speed control valve)
- HII air driven liquid pump
- Stainless steel tank with sight gauge and filler cap
- Outlet high pressure gauge
- Outlet shutoff valve and return to tank on/off valve



OPTIONAL HII COMPONENTS

- Outlet Pressure Relief Valves
- Pilot Cutoff Valve
- Chart Recorders
- High Pressure Hose Assemblies
- Flow Meters
- Filters



MARKETS SERVED

- General Manufacturing
- Mining
- Automotive
- Machine Tools
- Power & Energy
- Oil & Gas
- Diving
- Fire, Health & Safety
- Laboratory, University & Research
- Electronics & Computer
- Defense
- Railroad and more



OTHER HII QUALITY PRODUCTS

AIR DRIVEN GAS BOOSTERS

- Boosts pressure from 50 PSI (3.4 BAR) to 30,000 PSI (2068 BAR)
- Airline lubrication not required
- Lightweight, one-man portable
- Corrosion resistant including offshore environment
- Self-cooling using own exhaust air
- No electrical connections needed
- Wide range of models: single acting, double acting, two stage and double air drive configuration



ELECTRIC DRIVEN GAS BOOSTERS

- Boosts pressure from 50 PSI (3.4 BAR) to 10,000 PSI (689 BAR)
- Two-man portable
- Uses no belts or pulleys
- Quiet, only 65 dBa
- Offered in double acting and 2-stage configuration



AIR DRIVEN AIR PRESSURE AMPLIFIERS

- Boosting shop air to pneumatic tools, cylinders and devices
- Boosting shop air to drive high-pressure pneumatic diaphragm transfer pumps
- Boosting shop air to start oilfield and marine diesel engines
- Maximizing efficiency at pneumatic workstations or machinery
- Tire pressure top off on large mining vehicles
- Replace bottled nitrogen for gas testing, lab or production, up to 700 psi (48.3 BAR)

FLOWMETRICS

- Liquid Flowmeters - to 15,000 GPM (56,781 lit/min)
- Gas Flowmeters - to 15,000 CFM (425 Nm³/min)



COMPONENTS

- Check valves - up to 20,000 PSI (1379 BAR), up to 2"
- Needle valves - straight or angled to 5,000 PSI (345 BAR)
- In-line filters rated to 5,000 PSI (345 BAR), 3 to 25 micron
- Double acting hand pumps - to 3,000 PSI (207 BAR)
- Pressure relief valves - to 60,000 PSI (4137 BAR)

SYSTEMS

- Aircraft Ground Support Equipment (portable & stationary)
- Component Test Equipment
- Customer Designed Equipment
- Central Systems
- Commercial and Military Applications
- Self Propelled Aerial Lift Truck



Our products are designed, sourced and manufactured in the U.S.A.



HYDRAULICS INTERNATIONAL, INC. OVERVIEW

Founded in 1976, HII has evolved into a fully integrated manufacturer of hydraulic and pneumatic test equipment. HII maintains four modern facilities; three in Chatsworth, California and one in Forsyth, Georgia, totaling 690,000 square feet.

Along with air driven liquid pumps, HII offers air driven gas boosters, air pressure amplifiers, flowmeters, sophisticated custom systems and components. HII products are designed and manufactured in the USA.

■ **ISO 9001: 2008 & AS9100-2009 Certified Quality System**



CORPORATE HEADQUARTERS AND OFFICES, SALES, ADMINISTRATION, FABRICATION AND ASSEMBLY



ENGINEERING, ASSEMBLY AND TEST FACILITY



MACHINE SHOP FACILITY



AIRCRAFT COMPONENTS AND GSE MRO FACILITY

NOTES:

InstruMetrics
ENGINEERING



Hydraulics International, Inc.

HYDRAULICS INTERNATIONAL, INC.

9201 Independence Avenue, Chatsworth, CA 91311

Tel: (818) 407-3400 • Fax: (818) 407-3428 • Email: sales@hiipumps.com

www.hiigroup.com