



Vibration monitoring unit Series HE050



IO-Link



- Vibration velocity (mm/s, rms)
- Vibration acceleration (g, rms)
- Vibration acceleration (g, rms)
- Temperature (°C)
- Output 1: IO-Link or
Digital switching output
- Output 2: Analogue current output 4...20 mA or
Digital switching output
- Adjustable frequency range: 10 Hz ... 1000 Hz

Date of manufacture: _____

Type description: _____

Serial no.: _____

Operating instructions

Vibration Monitoring Unit Type HE050

Version: 2022-05-20

Attention!

Prior to commissioning the product, the instruction manual must be read and understood.

All rights reserved, including rights to translation.
Subject to modifications.

Please contact the company with any questions:

HAUBER-Elektronik GmbH

Fabrikstraße 6

D-72622 Nürtingen

Germany

Tel.: +49 (0) 7022 / 21750-0

Fax: +49 (0) 7022 / 21750-50

info@hauber-elektronik.de

www.hauber-elektronik.de

1 Inhaltsverzeichnis

1	Inhaltsverzeichnis	3
2	Safety information	4
3	Scope of this instruction manual	4
4	Vibration monitoring unit type HE050	5
5	Intended use	5
6	Scope of supply	5
7	Documents and certificates.....	5
8	Application areas and example labels	6
9	Information on the cULus validity range	6
10	Technical data.....	7
10.1	General data	7
10.2	Electrical data	8
10.3	Operating range of the vibration monitoring unit	9
10.4	Typical frequency response	10
10.5	Mechanical data.....	11
10.6	Housing dimensions.....	12
11	Connection.....	12
12	IO-Link description of functionality	13
12.1	Introduction	13
12.2	Software-parameterization service	13
12.3	General data	13
12.4	Measured values and process values	13
12.5	Outputs	13
12.6	Switching signal	14
12.7	Frequency ranges (Filter settings)	14
12.8	Maintenance Data.....	14
13	Installation and commissioning.....	15
13.1	General notes	15
13.2	Wiring diagram / earthing concept	15
14	Assembly and disassembly.....	17
14.1	General notes	17
14.2	Fixing the vibration monitoring unit to the mounting surface	17
15	Maintenance and repair	18
15.1	General notes	18
15.2	Troubleshooting Table	18
16	Transport, storage and disposal	19
17	Coding HE050.....	20
18	EU declaration of conformity.....	22

2 Safety information

2.1 General

The safety instructions are intended to protect people and property from damage and hazards that could arise as the result of improper use, incorrect operation or other misuse or devices, especially in explosive areas. Therefore, please read the operating instructions carefully before working on the product or operating it. The operating instructions must be accessible to operating personnel at all times.

Please make sure that all documents are present and complete before commissioning or performing other work on the product. If the documents have not all been delivered in full or if further copies are necessary, they can also be obtained in other languages.

The product is built according to the latest state of the art. However, hazards to people, machinery and systems can still arise as the result of improper handling, unintended use or operation and maintenance by persons inadequately trained on the product.

All those who are involved in the installation, operation and maintenance of the product in the operator's plant must read and understand the operating instructions.

The product may only be assembled, disassembled, installed and repaired by instructed, sufficiently trained and authorised personnel.

2.2 Symbols used



This symbol indicates a hazard from electrical current.



This symbol indicates safety-related information.



This symbol indicates information unrelated to safety.

3 Scope of this instruction manual

This instruction manual for the HE050-type vibration monitoring unit applies to all variants of the HE050.

4 Vibration monitoring unit type HE050

The HE050-type vibration monitoring unit is an IO-Link sensor for measuring of vibration velocity, vibration acceleration and temperature and is used to measure and monitor absolute bearing vibrations in machines in line with DIN ISO 10816.

It has the following features:

- Two individually configurable outputs
 - Output 1: IO-Link or digital switching output
 - Output 2: Analogue current output (4...20 mA) or digital switching output
 - Many settings available
- Adjustable frequency range 10 Hz... 1000 Hz. All available frequency ranges can be seen in "Frequency ranges (Filter settings)" on page 14.
- Optional safety integrity level SIL1

5 Intended use

The HE050-type is used exclusively for measuring mechanical vibrations and the temperature in machines and mechanical systems. Its use is only permissible within the specifications stated in the data sheet. **Main fields of application:** Fans, ventilators, blowers, electric motors, pumps, centrifuges, separators, generators, turbines and similar oscillating mechanical systems.



If the equipment is used in a manner not specified by the manufacturer, the protection provided by the equipment may be impaired.

6 Scope of supply

All variants include:

- Vibration monitoring unit
- Documentation

7 Documents and certificates

The following documents and certificates pertaining to type HE050 can be viewed and downloaded here: <https://www.hauber-elektronik.de/en>

- cULus certificate
- CE declaration of conformity
- User manual
- IO-Link description file

8 Application areas and example labels

Coding	HE050.0.0.x.xxx	HE050.1.0.x.xxx	HE050.0.1.x.xxx	HE050.1.1.x.xxx
	X	X	X	X
	E507077	E507077	E507077	E507077
Safety integrity level		SIL 1 Klassifizierung		SIL 1 Klassifizierung
Example labels	 Type: HE05x.0.0.0.002 Item-no.: 12345 Serial-no.: 123456 Measurement range: 16 mm/s Frequency Range: 10...1000 Hz -40°C ≤ Tamb ≤ +80°C IP66/67 Type 4X Enclosure	 Type: HE05x.0.0.0.002 Item-no.: 12345 Serial-no.: 123456 Measurement range: 16 mm/s Frequency Range: 10...1000 Hz -40°C ≤ Tamb ≤ +80°C IP66/67 Type 4X Enclosure	 Type: HE05x.0.1.0.001 Item-no.: 12345 Serial-no.: 123456 Frequency Range: 10...1000 Hz -40°C ≤ Tamb ≤ +80°C IP66/67 Type 4X Enclosure	 Type: HE05x.1.1.0.001 Item-no.: 12345 Serial-no.: 123456 Frequency Range: 10...1000 Hz -40°C ≤ Tamb ≤ +60°C IP66/67 Type 4X Enclosure
	 HAUBER-Elektronik GmbH 72622 Nürtingen GERMANY www.hauber-elektronik.de	 HAUBER-Elektronik GmbH 72622 Nürtingen GERMANY www.hauber-elektronik.de	 HAUBER-Elektronik GmbH 72622 Nürtingen GERMANY www.hauber-elektronik.de	 HAUBER-Elektronik GmbH 72622 Nürtingen GERMANY www.hauber-elektronik.de

Standards applied

You can find a list of standards, including the related issue dates, in the EU type examination certificate for the vibration monitoring unit.

9 Information on the cULus validity range

In order to install the device according to the UL/CSA/IEC standard, the following information must be observed.

Electrical protection



Devices must be protected by means of fuses, circuit breakers, overheating protection, impedance-limiting switches or similar to ensure protection against excessive power output if there is a fault in the device. Protection must be applied to supply lines and switching lines.



A circuit breaker suitable for 30V/3A according to UL Standard 489/CSA Standard (C22.2) no. 5/IEC 60947-2 must be installed near the device.



A fuse suitable according to UL Standard 248/CSA Standard (C22.2) no. 248/IEC 60127 must be installed near the device. The fuse must have a slow triggering characteristic ("T").

10 Technical data

10.1 General data



Both the measuring range and the frequency range can be adjusted via IO-Link.

Measurement accuracy:	$\pm 10\%$ (as per DIN ISO 2954) $\pm 0,5\%$ at calibration point
Calibration point	Variants w/o IO-Link: 90% of measuring range @ 159.2 Hz Variants with IO-Link: 1 g (rms) @159.2 Hz
Cross-sensitivity:	< 5%
Frequency range:	Selectable in the range of 10 Hz... 1000 Hz See also IO-Link description of functionality, page 13.
Maximum acceleration	± 15 g
Service life	10 years

Tab. 1: General data

10.2 Electrical data

Voltage supply:	18...30 V DC*
Current supply (max.):	700 mA

Output 1 (Pin 4)

Output signal:	IO-Link or switching output
----------------	-----------------------------

Output 2 (Pin 2)

Output signal:	4–20 mA (proportional to the measuring range) or switching output
----------------	---

Switching outputs

Output signal:	Digital I/O
Electrical execution:	PNP/NPN (configurable)
Output function:	Normally closed / normally open (low-active / high-active)
Switching levels:	0 V: Low 24 V: High High level equivalent to input voltage minus 2 V
Current draw per output (max.):	100 mA (Out 1) 500 mA (Out 2)
Short circuit protection:	yes*
Overload protection:	yes*

* Ensure that the supply line is protected by a UL-approved fuse for UL-compliant sensor operation.

Tab. 2: Electrical data

10.3 Operating range of the vibration monitoring unit

The operating range is independent of the measuring range. It is deduced from the maximum acceleration, which is 15 g across all frequencies. The maximum measurable vibration velocity is determined by the formula

$$v_{max} = \int a_{max}$$

The following applies to sinusoidal vibration

$$v_{max} = \frac{a_{max}}{2\pi f}$$

Fig. 1: shows the operating range of the vibration monitoring unit, which is limited by the maximum measurable vibration velocity in mm/s depending on the frequency in Hz.

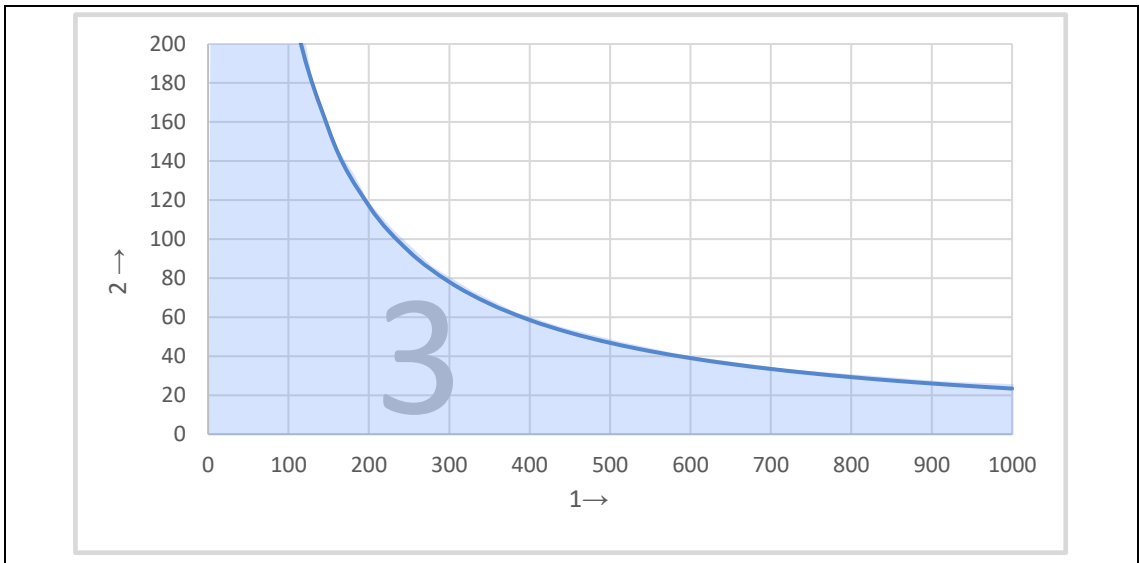

Fig. 1: Operating range diagram

- 1 Frequency in Hz
- 2 Vibration velocity in (mm/s, rms)
- 3 Operating range of the vibration monitoring unit

Reading examples:

Frequency (Hz)	Maximum measurable Vibration velocity (mm/s, rms)
250	93,6
400	58,5
1,000	23,4

Tab. 3: Operating range reading examples

10.4 Typical frequency response

10 Hz to 1,000 Hz

The frequency response is recorded using a reference sensor.

- 4 Hz. . . 1,200 Hz acceleration sensor

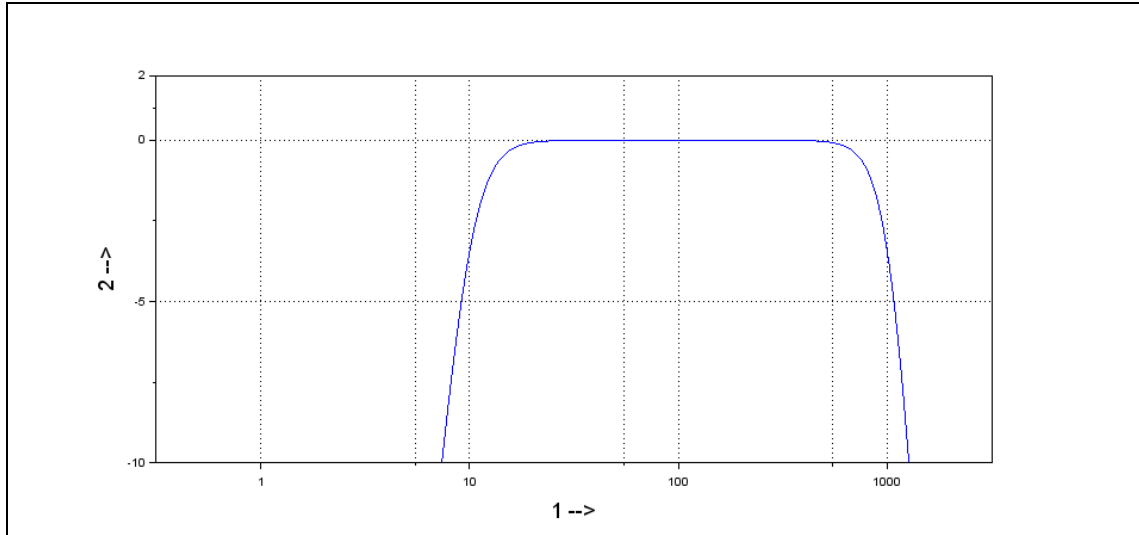

Fig. 2: Typical frequency response 10 Hz–1,000 Hz

- 1 Frequency in Hz
- 2 Amplification in dB

10.5 Mechanical data



Additional materials and fixings can be found in section "Coding HE050" on page 20.

Housing material:	Stainless steel V2A, material no.: 1.4305 (standard)
Fastening:	Width across flats 24 (hexagonal) M8 x 8 mm Pitch: 1.25 mm (standard)
Installation type:	standing/vertical or lying/horizontal
Measuring direction:	Along the fastening axis
Tightening torque sensor	8 Nm
Max. torque of the M12 union nut on the connector	0.4 Nm
Weight:	approx. 90 g
Protection class:	When connected: IP 66/67 Type 4X enclosure Product is suitable for outdoor use
Ambient temperature T_A :	$-40\text{ °C} \leq T_A \leq +80\text{ °C}$
Measuring head temperature T_M :	$-40\text{ °C} \leq T_M \leq +85\text{ °C}$
Max. humidity:	100%

Tab. 4: Mechanical data

10.6 Housing dimensions

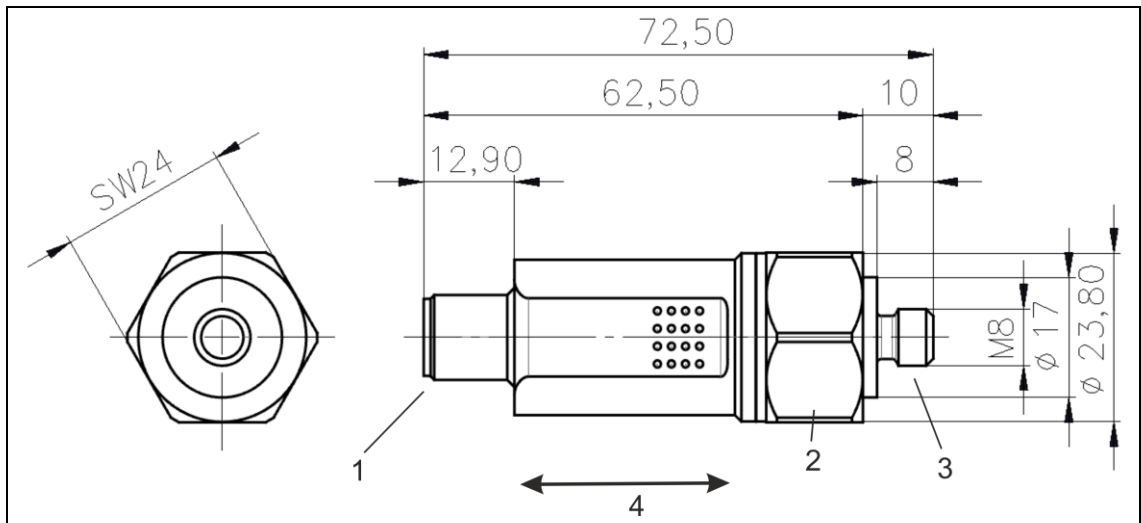

Fig. 3: Housing with M12 connector

All dimensions in mm

- 1 M12 connector
- 2 Width A/F 24
- 3 Fixing
- 4 Measuring direction along the fixing axis

11 Connection

Plug, M12, 4-pole

	Pin 1:	L+	18...30 V DC
	Pin 2:	Out 2	4...20 mA or switching output
	Pin 3:	L-	0V / GND
	Pin 4:	Out 1	IO-Link or switching output

12 IO-Link description of functionality

12.1 Introduction

IO-Link is the first standardised IO technology worldwide (IEC 61131-9) for the communication with sensors and also actuators. The powerful point-to-point communication is based on the long established 3-wire sensor and actuator connection without additional requirements regarding the cable material. So, IO-Link is no fieldbus but the further development of the existing, tried-and-tested connection technology for sensors and actuators.

To write and read data via IO-Link, an IO-Link master is required, which you can purchase separately.

12.2 Software-parameterization service

We offer the creation and application of bespoke parameters within the frame of possibilities which is given further on. Some sets of parameters can be found in chapter "Coding HE050" on page 20.

12.3 General data

Meets standards for IO-Link system and interface 1.1 (V.1.1.3)
Compliance IO-Link 1.1. Version 1.1.3 / Package 2020

All parameters and adresses are listed comprehensively within the IO-Link description file available in the download section of our [homepage](#). This chapter only serves as an overview of the products functions.

12.4 Measured values and process values

Following measured values and process values can be monitored via IO-Link continuously.

- Effective value vibration velocity (0,01 mm/s, rms)
- Effective value vibration acceleration (0,01 g, rms)
- Effective value vibration acceleration (0,01 g, peak)
- Temperature (1 °C)
- State of internal self test
- Error state
- State of all switching signals

12.5 Outputs

The two outputs can be configured as follows:

Output 1 acts, as soon as the sensor is connected to an IO-Link master, as the sensors IO-Link interface. Alternatively (When not connected to an IO-Link master) output 1 can be left unoccupied or act as a digital switching output.

Output 2 can either be configured as an analogue current output 4...20 mA or as a digital switching output. It can also be configured as "disabled". All measured values can be output as an analogue signal. The measuring range of the analogue signal can be freely set within a framework defined by the manufacturer.

12.6 Switching signal

Two configurable switching signals ("pre-alarm" and "main alarm") are available in the sensor for each measured or process variable, which can be output via IO-Link or one of the two outputs configured as a switching contact.

The following settings can be configured individually for each switching signal:

- Limit values (in the respective unit of the measurement parameter)
- Time delay in ms (1 ms ... 60000 ms)
- Mode:
 - o 0: deactivated
 - o 1: Alarm function ('single Point'). In this mode, the limit value 2 is ignored.
 - o 2: Window function, i.e., the signal switches as soon as the limit value falls below 2.
- Hysteresis:
 - o Describes the switching delay in terms of the limit. In the standard version, this is fixed at 2% and can only be freely configured for the temperature (0 K ... 20 K)

12.7 Frequency ranges (Filter settings)

Four predefined frequency ranges can be selected:

0: 10 Hz ... 1000 Hz

1: 10 Hz ... 500 Hz

2: 10 Hz ... 100 Hz

3: 10 Hz ... 50 Hz

12.8 Maintenance Data

Following data is available exclusively via IO-Link and cannot be output via any other output.

Counter

It is possible to set a third limit value for each measured value and for each process value (independent of the previously mentioned switching signals). Regarding this limit value there is a counter for the number of exceedances and another counter for the total duration of all exceedances. An IO-Link event reporting the exceedance of a defined counter reading can be created for both counters.

13 Installation and commissioning

13.1 General notes

Installation and commissioning the vibration monitoring unit must be performed by an authorised specialist who is familiar with the safety regulations when handling electrical components.



Protect the connection cable and any extension cables from electrical interference or mechanical damage. Comply with the local regulations and directives.



The cable used for the supply connection shall be suitable for the environmental condition.

We recommend HAUBER Cable Type C

- 2 m (HAUBER Item.-No.: 12960)
- 5 m (HAUBER Item.-No.: 12961)
- 10 m (HAUBER Item.-No.: 11888)

Please contact us for further cable lengths.

13.2 Wiring diagram / earthing concept

Earth/ground loops are amongst the most common problems in measurement set-ups with sensitive sensor technology. These issues arise due to unintentional differences in potential in the electrical circuit between the sensor and evaluation unit.



Ensure that the earth connection is electrically secure.

According to the earthing concept, the cable shielding is electrically connected to the sensor housing through the knurled nut and has earth potential at the evaluation unit. With greater cable lengths it is favorable to disconnect the shielding from the evaluation unit (4) in order to prevent compensating currents over the shielding.



Abb. 4: Standard earthing concept

1 Machine earth

- 2 Evaluation unit (measuring device, SPS, IO-Link Master...)
- 3 Cable shield
- 4 Evaluation unit earth potential

14 Assembly and disassembly

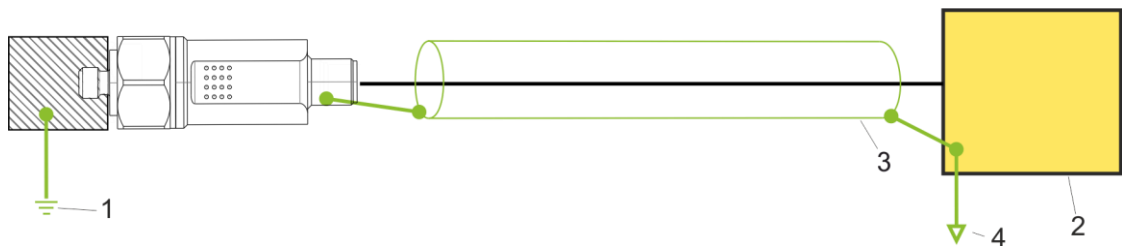
14.1 General notes

Assembly and disassembly work on and with the vibration monitoring unit may only be performed by an authorised specialist familiar with the safety regulations governing handling electrical components.



The housing of the vibration monitoring unit must be earthed via the fixing – through the machine earth of the mounting surface or through a separate protective conductor (PE).

14.2 Fixing the vibration monitoring unit to the mounting surface

Prerequisites

- Mounting surface is clean and flat; i.e. free of paint, rust, etc.
- Measuring head area of the vibration monitoring unit must lie flat on the mounting surface.

Tool

- 24 mm wrench

Work steps and instructions

- Screw vibration monitoring unit into the threaded hole of the mounting surface in a friction-locked manner using a hex key. The tightening torque should be 8 Nm.
- The tightening torque of the M12 union nut of the plug connection must not exceed 0.4 Nm



To obtain precise measurement values, the vibration monitoring unit must be fixed to the mounting surface in a friction-locked manner.



Auxiliary structures for fixing are to be avoided. If unavoidable, make them as firm as possible!



Earth/ground loops are amongst the most common problems in measurement set-ups with sensitive sensor technology. These issues arise due to unintentional differences in potential in the electrical circuit between the sensor and evaluation unit. As a countermeasure, we recommend our earthing concept



Ensure that the earth connection is electrically secure.

15 Maintenance and repair

15.1 General notes



Repair and cleaning work on vibration monitoring units may only be performed by an authorised specialist familiar with the safety regulations governing handling electrical components.



Before repair and cleaning disconnect the monitoring unit from the power supply! Separate plug connections must always be de-energized!



Immediately replace defective connection cables!
A defective vibration monitoring unit must be completely replaced!



The vibration monitoring unit HE050 is maintenance-free!

15.2 Troubleshooting Table

Fault	Cause	Action
No measured value (4-20 mA)	No power supply	Check power source and/or supply
	Analogue signal disabled	Enable analogue signal
	Discontinuity in connecting cable	Replace connecting cable
	Fuse defective	Replace fuse
	Connection has incorrect polarity	Connection of correct pole
	Vibration monitoring unit defective	Replace vibration monitoring unit
Relay does not switch	Wrong limit value set	Set correct limit value
	No power supply	Check power source and/or supply
	Discontinuity in connection	Replace connecting cable
	Fuse defective	Replace fuse
	Connection has incorrect polarity	Connection of correct pole
	Defective monitoring unit	Replace monitoring unit
False reading	Vibration monitoring unit not friction-locked.	Friction lock vibration monitoring unit.
	Vibration monitoring unit installed in wrong place	Install vibration monitoring unit in correct place
	EMC problems	"earthing concept" on page 15.

Tab. 5: Troubleshooting Table

16 Transport, storage and disposal

The sensor must be protected from damaging environmental factors and mechanical damage during transport with the use of adequate packing.

The sensor may not be stored in ambient temperatures outside the permitted operating temperature.

The product contains electronic components and must be disposed of properly in accordance with local laws and regulations.

17 Coding HE050

HE050.	0.	1.	0.	001
--------	----	----	----	-----

HE series

050 = IO link sensor

Certifications

0 = CE / IEC / cULus / EAC
 1 = CE / IEC / cULus / EAC + SIL 1

IO link

0 = No IO-Link
 1 = IO-Link (Alternative Function for OUT 1)

Housing

0 = 1.4305 (V2A) with fastening M8 x 8 mm; incline 1.25 (Standard)
 1 = 1.4404 (V4A) with fastening M8 x 8 mm; incline 1.25 mm
 2 = 1.4462 duplex stainless steel with fastening M8 x 8 mm; incline 1.25 mm

Software parameter settings (factory default)

	Output 1	Output 2
001 =	IO-Link	-
012 =	-	4...20 mA ~ 0...8 mm/s, rms; 10 Hz ...1000 Hz
013 =	-	4...20 mA ~ 0...10 mm/s, rms; 10 Hz ...1000 Hz
002 =	-	4...20 mA ~ 0...16 mm/s, rms; 10 Hz ...1000 Hz
014 =	-	4...20 mA ~ 0...20 mm/s, rms; 10 Hz ...1000 Hz
003 =	-	4...20 mA ~ 0...25 mm/s, rms; 10 Hz ...1000 Hz
004 =	-	4...20 mA ~ 0...32 mm/s, rms; 10 Hz ...1000 Hz
005 =	-	4...20 mA ~ 0...50 mm/s, rms; 10 Hz ...1000 Hz
006 =	-	4...20 mA ~ 0...64 mm/s, rms; 10 Hz ...1000 Hz
015 =	-	4...20 mA ~ 0...1 g, rms; 10 Hz ...1000 Hz
016 =	-	4...20 mA ~ 0...2 g, rms; 10 Hz ...1000 Hz
017 =	-	4...20 mA ~ 0...4 g, rms; 10 Hz ...1000 Hz
018 =	-	4...20 mA ~ 0...6 g, rms; 10 Hz ...1000 Hz
019 =	-	4...20 mA ~ 0...8 g, rms; 10 Hz ...1000 Hz
020 =	-	4...20 mA ~ 0...10 g, rms; 10 Hz ...1000 Hz
021 =	-	4...20 mA ~ 0...12 g, rms; 10 Hz ...1000 Hz



Don't see your desired configuration listed? Please contact us and we can offer you a solution for your specific needs.

18 EU declaration of conformity

Declaration of conformity

HAUBER-Elektronik GmbH
Fabrikstraße 6
D-72622 Nürtingen-Zizishausen

declares under our sole responsibility that the products listed below that relate to this declaration meet the basic health and safety requirements of the norms and directives below.

Product series

HE050, HE055

Signature

Nürtingen, 17/02/2022

Place and date

Norms and directives

EU Directive	Norms
2014/30/EU	EN 61000-6-7:2005 EN 61000-6-3:2007 + A1:2011 EN 55011:2016 + A1:2017



Tobias Bronkal, Managing Owner