

AIR DRIVEN GAS BOOSTERS

Hydraulics International, Inc.

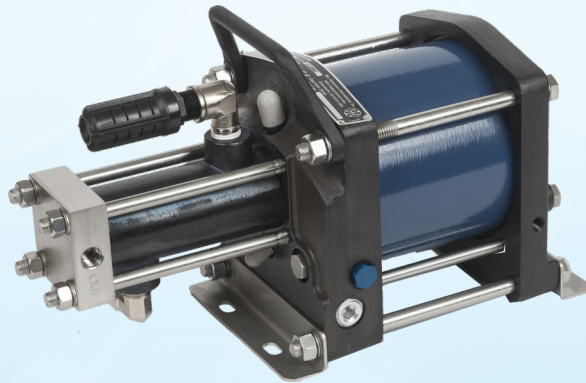
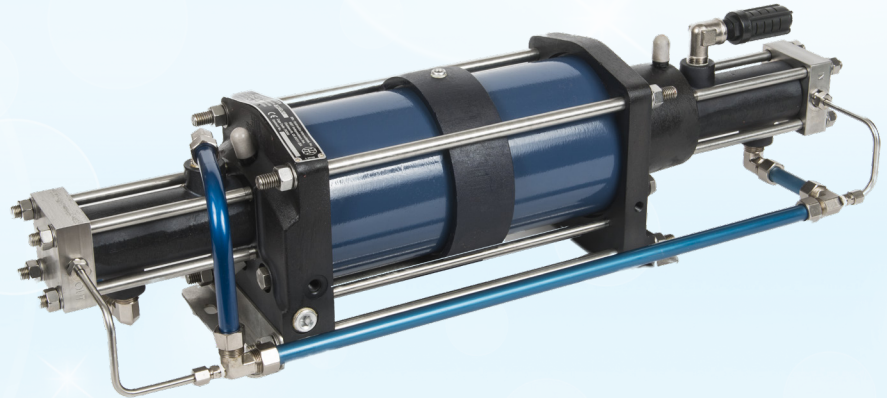

InstruMetrics
ENGINEERING

CONTENTS

■ Principle of Operation, Benefits, Features, Typical Gas Booster Applications.....	2	■ How to Use the Performance Curves.....	9
■ Why Use Air Driven Gas Boosters?, International Equivalents.....	3	■ Performance Curves.....	9, 10, 11, 12
■ How Do Buyers Choose Between Gas Booster Models?.....	3, 4	■ Installation Dimensions, Weights.....	13, 14
■ Determining the Proper Gas Booster Model—Examples.....	4, 5	■ Standard Modifications.....	15
■ Gas Booster Selection Table and Notes.....	6, 7, 8	■ Hydraulics International, Inc. Overview.....	15
		■ Other HII Products.....	16

PRINCIPLE OF OPERATION

An air (or gas) driven gas booster has a continuously reciprocating drive piston section directly connected to one or two gas boosting sections, as illustrated in Figure 1. The drive section includes a four-way air cycling valve and dual air pilot valves to provide the continuous reciprocation. Normally, start/stop control is accomplished by cutting off drive- or pilot-air input. (For description of gas section operation, see Page 3, Volumetric Efficiency.)

Maximum Gas Section Pressures vary by model and are detailed on Pages 6 and 7.

Maximum Drive Section Pressure is 150 PSI for all models.

Drive Input Port is 1/2" SAE Boss. (Ref. Table 4, Page 8)

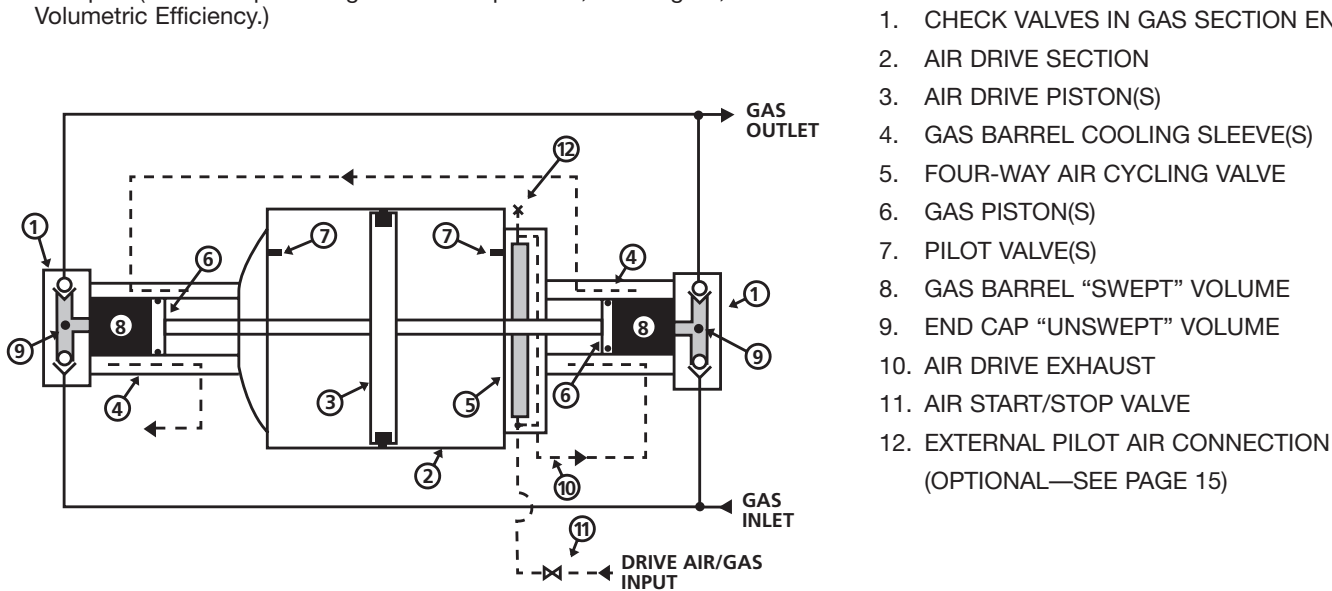

Figure 1. Typical Double Acting, Single Drive, Single Stage Unit (Model 5G-DS-Ratio)

BENEFITS OF GAS BOOSTERS

- High pressure capability - up to 25,000 PSI.
- Boost directly from unregulated high pressure gas cylinders or pipelines.
- Maintain gas purity.
- One-man portable.
- No electrical or cooling connections needed.
- Intrinsically safe.
- Boost virtually any noncorrosive industrial or laboratory gas.
- Simple maintenance.
- Mount in any position.
- Weatherproof.

FEATURES OF GAS BOOSTERS

- Separation between drive and gas section uses three dynamic seals with dual vents.
- Air drive line lubrication not required.
- Rugged soft-seat, high-flow check valves in gas section(s).
- Only hydrocarbon-free stainless steel, bronze, PTFE and Viton gas section internal parts exposed to gas flow.
- Heat of compression reduced for long seal life because cold exhaust air surrounds gas barrel(s) inside cooling sleeve(s) (see Figure 1, Item 4 above).
- Standard trim is weatherproof and suitable for offshore service.

TYPICAL GAS BOOSTER APPLICATIONS

- **Pressure Testing Piping and Hardware for Leakage:** e.g., oil field, refinery, aircraft, automotive, instrumentation using gases.
- **Gas Injection:** chemical process, plastic forming.
- **Gas Scavenging:** collecting costly gas in partially used cylinders and transferring it into high pressure receiver(s) for further use.
- **Life Support Gas Transfer and Charging:** e.g., oxygen, helium, breathing air, diving, fire fighting/hazmat, aircrew.
- **Compressed Natural Gas (CNG) Boosting** for vehicle refueling stations.

WHY USE AIR DRIVEN GAS BOOSTERS?

GAS PURITY: Most gases used in industry and life support must be clean and dry. Otherwise, the end use is severely compromised. Gases needing purity include argon(Ar), carbon dioxide(CO₂), helium(He), hydrogen(H₂), neon(Ne), nitrogen(N₂), nitrous oxide(N₂O), oxygen(O₂) and breathing air. If gas purity is needed, all devices used to transfer gas or increase gas pressure must be completely dry and free of any lubricants. Hydraulics International, Inc.'s (HII's) air driven gas boosters satisfy this requirement. No hydrocarbon lubrication is needed in the gas sections because the high pressure pistons slide on inert PTFE dynamic seals. And because gas barrel temperature is controlled with the cold drive air exhaust, long seal life is ensured.

HIGH PRESSURE OUTLET: Most mechanically driven gas compressors can only handle 5,000- to 6,000-PSI requirements. Mechanically driven units that can handle over 6,000 PSI are rare and costly. If gas purity is required, most of these higher-PSI units need high-pressure and high-maintenance purifiers installed—to compensate for hydrocarbon carryover created by oil-lubricated pistons.¹ Air driven gas boosters do not suffer from these shortcomings and are therefore better suited for higher-PSI applications. HII's standard air driven models are hydrocarbon-free and available in 50- to 25,000-PSI capacities.

BOOST DIRECTLY FROM HIGH PRESSURE GAS CYLINDERS:

A mechanical compressor cannot inhale common industrial gas cylinder pressure. The inlet pressure must be reduced, usually close to 0 PSI. This is a costly waste of energy. Air driven gas boosters have no such limitation, greatly enhancing the efficiency and simplicity of high pressure gas applications where the gas source is typically supplied from portable DOT cylinders.

When are compressors better than air driven gas boosters?

LOW-PRESSURE GAS SUPPLY: Compressor design typically provides piston speeds 10 to 20 times faster than air driven gas boosters. The output of the compressor at 0 PSI inlet is therefore 10 to 20 times higher than the gas booster's. For the gas booster to compete, the gas supply inlet pressure should be 10 to 20

times higher (10 to 20 ATM, i.e., 150 PSI or better).

GAS PURITY UNIMPORTANT: Lubricated compressors are already designed to handle the contamination of their own lubrication. If the supply gas is also not clean, the compressor probably is not bothered. But the air driven gas booster is designed to depend on a pure, oil-free, water-free gas supply.

When can air driven gas boosters and mechanically driven compressors work together?

USE A MECHANICAL COMPRESSOR FROM LOW PRESSURE TO MEDIUM PRESSURE (e.g., 3,000 PSI). THEN PURIFY. THEN BOOST TO HIGH PRESSURE WITH A GAS BOOSTER. This classic setup uses the attributes of each machine to complement the other. It has, for example, become the accepted combination for high pressure breathing air fill systems worldwide:

SCBA - (Self Contained Breathing Apparatus) and
SCUBA - (Self Contained Underwater Breathing Apparatus).

INTERNATIONAL EQUIVALENTS QUICK REFERENCE

VOLUME:

1 Litre = 61 In³ = .26 US Gal.

1 NM³ = 35.3 SCF

PRESSURE:

1 BAR = 14.5 PSI = 1.02 Kg/Cm² = 100 Kpa = .986 Absolute ATM

1 Mpa = 10 BAR = 1000 Kpa

1 Absolute ATM = 14.7 PSIA = 0 PSI

WEIGHT:

1 Kg = 2.2 Lb.

LENGTH:

1 In = 25.4 mm

HOW DO BUYERS CHOOSE BETWEEN GAS BOOSTER MODELS?

EFFICIENCY vs. COST

The selection of most production equipment involves an efficiency/cost trade-off. In the case of gas boosters, considering the frequency of usage (sporadic vs. continuous) and type of usage (light vs. heavy duty) helps in the trade-off decision. For continuous heavy-duty usage, an efficient gas booster will pay for itself in reduced power consumption (drive air) and lower maintenance. If usage will be sporadic and light duty, meaning energy consumption will not be an issue, it is better to select a less costly, less efficient gas booster. The final decision becomes trickier when usage will fall between the extremes of sporadic vs. continuous or light vs. heavy. That's when understanding volumetric efficiency becomes important.

VOLUMETRIC EFFICIENCY

Mechanical efficiency is about the same for all gas boosters, making it a nonissue in selecting among models. But gas booster buyers do need to consider volumetric efficiency. Volumetric efficiency relates to the gas booster's efficiency in moving the gas from stroke to stroke. Because all gases are compressible fluids, the volumetric efficiency of a gas booster varies widely from application to application depending on what compression ratio is

encountered. To understand this, refer to Figure 1 on Page 2. A gas piston cycle consists of a compression stroke and a suction stroke. During the compression stroke, the gas compresses from "swept" into "unswept" space; during the suction stroke, the gas flows back from unswept into swept space. If the gas is compressed to a very high ratio during the compression stroke, the unswept gas may come back during the suction stroke at a residual pressure high enough that the inlet supply pressure cannot open the inlet check valve. When this happens, volumetric efficiency and outlet gas flow reach zero, i.e., the unit has reached its maximum compression ratio; (chart 1, page 4).

At the other extreme, the gas in the unswept spaces is compressed very little by the compression stroke. In this case, as soon as the gas piston starts back on its suction stroke, the swept pressure immediately drops below the inlet supply pressure, the inlet check valve pops open, and a full charge of fresh gas is inhaled by the swept volume of the suction stroke. Volumetric efficiency reaches about 99%, meaning that the maximum amount of gas is moved from the gas supply to the outlet receiver during each cycle. Here the compression ratio is very low.

¹ A few manufacturers do offer higher-PSI gas compressors that have oil-free dry pistons or oil-free metal diaphragms. These units are costly and limited in supply; they are usually used only in chemical-process and corrosive-gas applications.

HOW DO BUYERS CHOOSE BETWEEN GAS BOOSTER MODELS? (continued)

COMPRESSION RATIO

Volumetric efficiency of gas boosters is affected by unswept space, internal leakage, and compression ratio. HII's gas boosters are designed and manufactured to ensure unswept space is minimal and internal leakage is nonexistent. The compression ratio is therefore the most important factor to consider in selecting which HII model will provide the highest volumetric efficiency. To calculate or estimate the compression ratio, the outlet and inlet gas pressures must be known. If both outlet and inlet gas pressure are less than or equal to 5,000 PSI:

$$\text{Compression Ratio} = \frac{\text{Outlet PSIA}}{\text{Inlet PSIA}}$$

where both values < 5,000 and PSIA = PSI + 14.7.

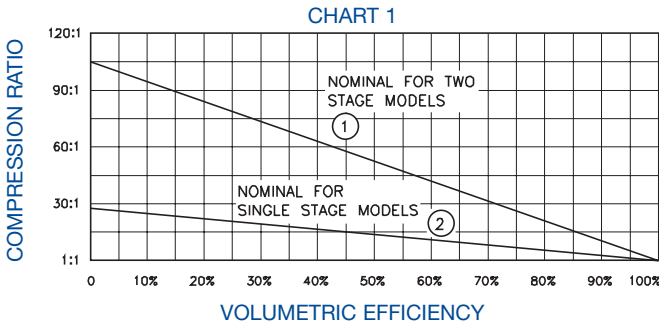

If either inlet gas pressure or outlet gas pressure exceeds 5,000 PSI, consult Chart 2 below and calculate the compression ratio as:

$$\text{Compression Ratio} = \frac{\text{Compress Factor for Outlet PSI}}{\text{Compress Factor for Inlet PSI}^*}$$

where either value > 5,000.

*If inlet gas pressure is less than or equal to 5,000 PSI, the Compress Factor for Inlet PSI (to be plugged into above equation) can be estimated from Chart 2 or calculated as:

$$\text{Compress Factor for Inlet PSI} = \frac{(\text{Inlet PSI} + 14.7)}{14.7}$$

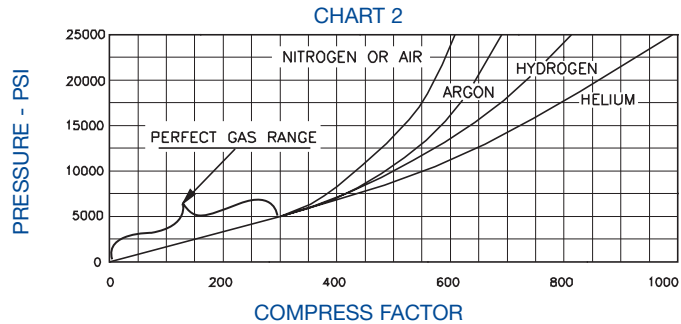

Note: Contact HII for compression data of other gases.

DETERMINING THE PROPER GAS BOOSTER MODEL – EXAMPLES

Example 1: You have marginal 100 PSI shop air drive pressure and need to test pressure gauges or transducers occasionally in your lab to 3,000 PSI minimum. Gas supply is high-purity helium in cylinders at 2,000 PSI. You should leave no more than 10% of the helium before returning the cylinder to your gas supplier.

Duty: light (occasional use, small test volumes).

Compression ratio, depleted cylinder (worst case):

$$\frac{3014.7 \text{ PSIA Outlet}}{201.47 \text{ PSIA Inlet (10\% of 2014.7)}} = 15 : 1$$

Compression ratio, fresh cylinder (best case):

$$\frac{3014.7 \text{ PSIA Outlet}}{2014.7 \text{ PSIA Inlet}} = 1.5 : 1$$

MODEL SELECTION: Single Acting, Single Drive, Single Stage (lowest cost). Per Chart 1, Line 2, efficiency is

about 40% at 15:1 (worst) to 98% at 1.5:1 (best).

From the stall point data, Table 1 on Page 6, pick a model that will easily reach 3,000 PSI with less than 100 PSI drive (Model 5G-SS-50). If time-to-test predictions are important, use the curves on Page 10 to estimate output flows as inlet pressure decreases.

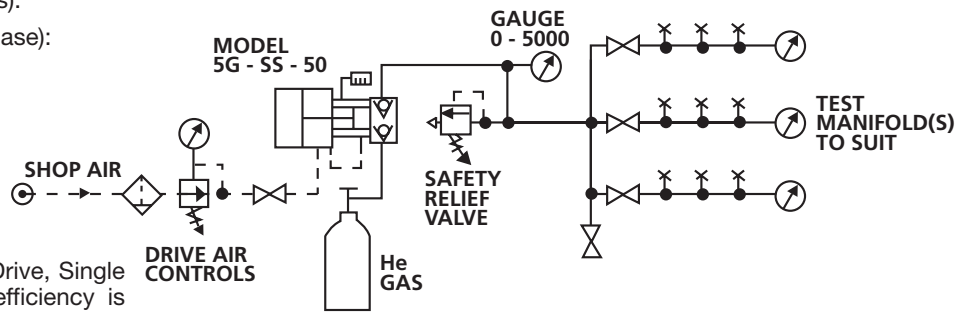

Example 2: Assume same helium, same 3,000 PSI minimum, and same marginal 100 PSI shop air drive pressure as Example 1. But this time, your job is to charge 100-gallon gas receivers (for saturation divers) on a diving contractor's barge.

Duty: heavy daily use.

Same compression ratios as Example 1.

At 3,000 PSI, the 100 Gal. receiver holds 2742 SCF:

$$\frac{100 \text{ Gal.}}{7.48 \text{ Gal./SCF}} \times \frac{3014.7 \text{ PSIA}}{14.7 \text{ PSIA}} = 2742 \text{ SCF}$$

MODEL SELECTION: Two Stage for High Efficiency. Per Chart 1, Line 1, efficiency is about 85% at 15:1 (worst) to 98% at 1.5:1 (best).

From the stall-point data, Table 1 on Page 6, pick a model that will reach 3,000 PSI with 95 PSI drive, yet not be subject to interstage stall (see Note (c) on Page 8). Model 5G-TS-30/50 appears to meet this requirement. But if outlet flow for this model (per curve on Page 10) is marginal to

meet receiver fill time required, there are two potential solutions. You could use multiple two stage units; or set up two or more double acting, single stage models in a series to provide two stages of compression, as illustrated in Example 4 on Page 5.

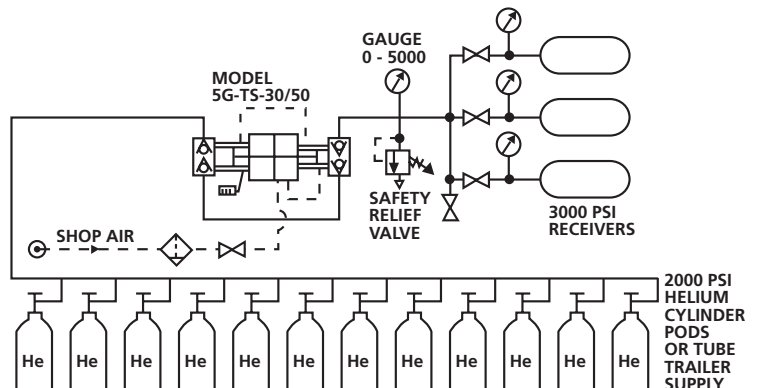

DETERMINING THE PROPER GAS BOOSTER MODEL—EXAMPLES (continued)

Example 3: You have a constant 4,000 PSI nitrogen supply (from an LN₂ 4,000 PSI pump and vaporizer); on a semi-monthly basis, you need to leak-check oil field valves to 17,500 PSI per API specification. Shop air drive pressure of about 100 PSI is available.

Duty: moderate.

Per Chart 2, Compress Factor for 17,500 PSI outlet is 550.

Compress Factor for 4,000 PSI Inlet is 273 obtained by using Chart 2 or the Compress Factor for Inlet PSI equation (4014.7 PSIA/14.7 PSIA).

Compression ratio, worst case:

$$\frac{550 \text{ Compress Factor for Outlet PSI}}{273 \text{ Compress Factor for Inlet PSI}} = 2:1$$

MODEL SELECTION: Single Stage, Double Acting, Double Drive to be able to reach 17,500 PSI. Per Chart 1, Line 2, efficiency is about 90% at 2:1.

See stall-point data on Table 1, Page 6. Note that no single acting, single stage model can reach 17,500 PSI with 95 PSI drive, but double acting model 5G-DD-150 can. Two-stage models-28/150 and -60/150 cannot accept the 4,000 PSI inlet for reasons discussed in Notes (b) and (c) on Page 8.

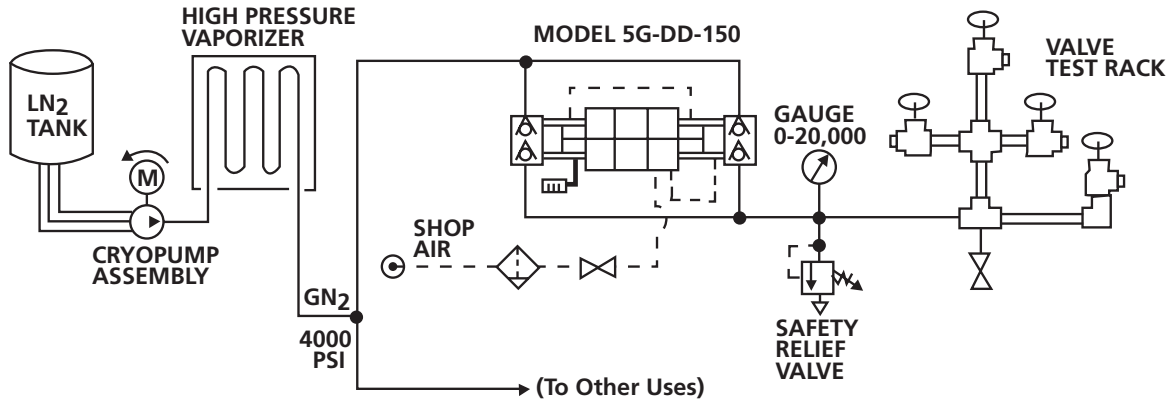

Example 4: A large-metropolitan ambulance service purchases liquid oxygen (LOX) because of the high volume consumed daily. The cost saved per cubic foot of oxygen is substantial vs. buying the gas in cylinders. (Purchasing LOX was recommended by their O₂ supplier when their consumption began to exceed 50 cylinders per month.) Their on-site LOX storage is a large insulated “customer station” tank, refilled regularly by LOX tank truck. The external vaporizer coils of the tank provide O₂ at 200 PSI maximum. They need to fill small 2,000 PSI oxygen bottles for the ambulance fleet seven days a week, four to five hours per day. Duty: heavy (8 to 10 SCFM outlet flow specified from a constant low pressure source).

Compression ratio (worst case):

$$\frac{2014.7 \text{ PSIA Outlet}}{214.7 \text{ PSIA Inlet}} = 9.4:1$$

MODEL SELECTION: Two Stage, Using Two Single Stage Boosters Piped in a Series.

Using the curves on Pages 10-12 and the guide on Page 9, the proper staged combination would be:

First stage: Model 5G-DS-7

Second stage: Model 5G-DD-28²

Per Chart 1, Line 2, assuming each unit will see about half the compression ratio (4.7:1), efficiency is about 85% for each unit.

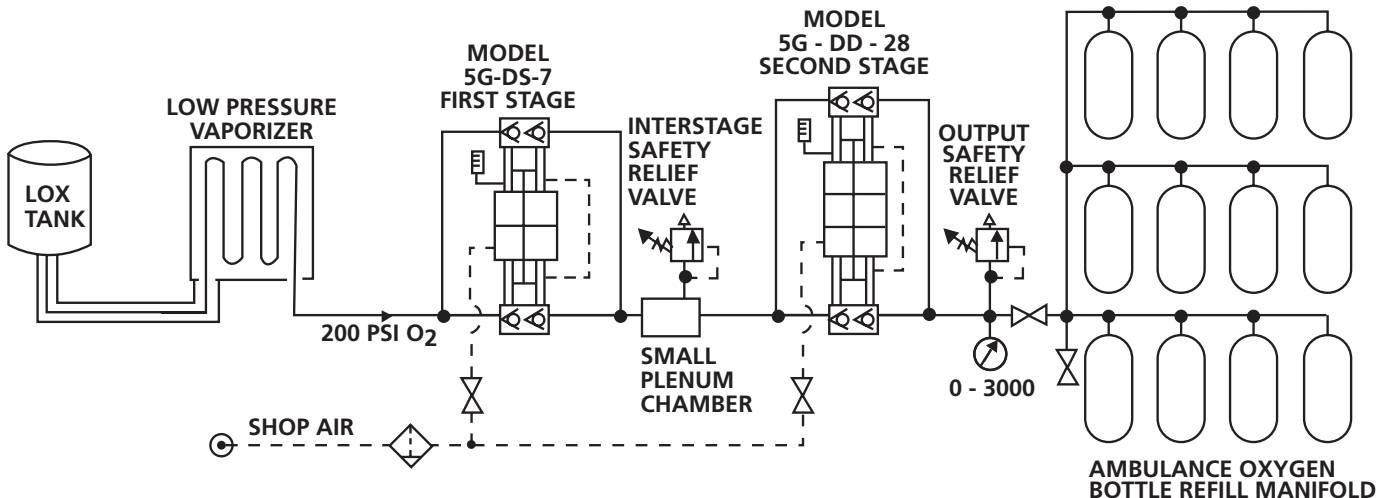

² Another possible second stage model is 5G-DS-30. But this lower-cost model has less than half the displacement per cycle of Model 5G-DD-28, causing higher potential maintenance.

TABLE 1. GAS BOOSTER SELECTION TABLE - SEE PAGE 8 FOR IMPORTANT NOTES

Model (Note: Final Dash No. is Area Ratio)	Schematic Symbol	Approximate Stall Point:		Maximum Safe Pressure ^(a) PSI		Actual In ³ Per Cycle	
		$\left(\text{Area Ratio} \times \text{Drive Air PSI} \right)$	$\left(\text{Assist Factor} \times \text{Gas Inlet PSI} \right)$	Outlet	Inlet		
Single Acting, Single Drive (Single Stage)							
1.	5G-SS-7		7 x Drive Air (No assist from gas inlet)		2,500	2,500	13.20
2.	5G-SS-14		14 x Drive Air (No assist from gas inlet)		4,500	4,500	7.00
3.	5G-SS-30		30 x Drive Air (No assist from gas inlet)		9,000	9,000	3.10
4.	5G-SS-50		50 x Drive Air (No assist from gas inlet)		15,000	15,000	1.76
5.	5G-SS-75		75 x Drive Air (No assist from gas inlet)		30,000	30,000	1.20
Single Acting, Double Drive (Single Stage)							
6.	5G-SD-60		60 x Drive Air (No assist from gas inlet)		9,000	9,000	3.10
7.	5G-SD-100		100 x Drive Air (No assist from gas inlet)		15,000	15,000	1.76
8.	5G-SD-150		150 x Drive Air (No assist from gas inlet)		30,000	30,000	1.20
Double Acting, Single Drive (Single Stage)							
9.	5G-DS-4		(4 x Drive Air) + (1.00 x Gas Inlet)		1,250	1,250	24.10
10.	5G-DS-7		(7 x Drive Air) + (1.00 x Gas Inlet)		2,500	2,500	26.40
11.	5G-DS-14		(14 x Drive Air) + (1.00 x Gas Inlet)		4,500	4,500	14.00
12.	5G-DS-30		(30 x Drive Air) + (1.00 x Gas Inlet)		9,000	9,000	6.20
13.	5G-DS-50		(50 x Drive Air) + (1.00 x Gas Inlet)		15,000	15,000	3.52
14.	5G-DS-75		(75 x Drive Air) + (1.00 x Gas Inlet)		30,000	30,000	2.40
Double Acting, Double Drive (Single Stage)							
15.	5G-DD-14		(14 x Drive Air) + (1.00 x Gas Inlet)		2,500	2,500	26.40
16.	5G-DD-28		(28 x Drive Air) + (1.00 x Gas Inlet)		4,500	4,500	14.00
17.	5G-DD-60		(60 x Drive Air) + (1.00 x Gas Inlet)		9,000	9,000	6.20
18.	5G-DD-100		(100 x Drive Air) + (1.00 x Gas Inlet)		15,000	15,000	3.52
19.	5G-DD-150		(150 x Drive Air) + (1.00 x Gas Inlet)		30,000	30,000	2.40
Two Stage, Single Drive							
20.	5G-TS-4		(4 x Drive Air) + (1.00 x Gas Inlet)		1,250	1,250 (b)	12.00
21.	5G-TS-7/14		(14 x Drive Air) + (2.00 x Gas Inlet) (b,c)		4,500	2,500 (b)	13.20
22.	5G-TS-7/30		(30 x Drive Air) + (4.29 x Gas Inlet) (b,c)		9,000	2,500 (b)	13.20
23.	5G-TS-7/50		(50 X Drive Air) + (7.14 X Gas Inlet)(b,c)		15,000	2,500 (b)	13.20
24.	5G-TS-14/30		(30 x Drive Air) + (2.14 x Gas Inlet) (b,c)		9,000	4,500 (b)	7.00
25.	5G-TS-14/50		(50 x Drive Air) + (3.57 x Gas Inlet) (b,c)		15,000	4,500 (b)	7.00
26.	5G-TS-14/75		(75 x Drive Air) + (5.36 x Gas Inlet) (b,c)		30,000	4,500 (b)	7.00
27.	5G-TS-30/50		(50 x Drive Air) + (1.66 x Gas Inlet) (b,c)		15,000	9,000 (b)	3.10
28.	5G-TS-30/75		(75 x Drive Air) + (2.50 x Gas Inlet) (b,c)		30,000	9,000 (b)	3.10
29.	5G-TS-30/92		(92 x Drive Air) + (3.06 x Gas Inlet) (b,c)		30,000	9,000 (b)	3.10
30.	5G-TS-50/92		(92 x Drive Air) + (1.84 x Gas Inlet) (b,c)		30,000	15,000 (b)	1.76
Two Stage, Double Drive							
31.	5G-TD-14/28		(28 x Drive Air) + (2.0 x Gas Inlet) (b,c)		4,500	2,500 (b)	13.20
32.	5G-TD-14/60		(60 x Drive Air) + (4.28 x Gas Inlet) (b,c)		9,000	2,500 (b)	13.20
33.	5G-TD-28/60		(60 x Drive Air) + (2.14 x Gas Inlet) (b,c)		9,000	4,500 (b)	7.00
34.	5G-TD-28/100		(100 x Drive Air) + (3.57 x Gas Inlet) (b,c)		15,000	4,500 (b)	7.00
35.	5G-TD-28/150		(150 x Drive Air) + (5.36 x Gas Inlet) (b,c)		30,000	4,500 (b)	7.00
36.	5G-TD-60/100		(100 x Drive Air) + (1.66 x Gas Inlet) (b,c)		15,000	9,000 (b)	3.10
37.	5G-TD-60/150		(150 x Drive Air) + (2.50 x Gas Inlet) (b,c)		30,000	9,000 (b)	3.10

Port Detail		Approximate Envelope Dimensions—Inches Length, Height, Width & Weight (See Page 13 & 14 for more details)
Out	In	
1/2" SAE	1/2" SAE	17 L x 10 H x 10 W, 27 lb
(d)	(d)	17 L x 10 H x 10 W, 23 lb
(d)	(d)	17 L x 10 H x 10 W, 23 lb
(d)	(d)	17 L x 10 H x 10 W, 23 lb
(e)	(d)	17 L x 10 H x 10 W, 23 lb
(d)	(d)	24 L x 10 H x 10 W, 31 lb
(d)	(d)	24 L x 10 H x 10 W, 31 lb
(e)	(d)	24 L x 10 H x 10 W, 31 lb
5/8" SAE	5/8" SAE	18 L x 10 H x 10 W, 30 lb
1/2" SAE(f)	1/2" SAE(f)	26 L x 10 H x 10 W, 48 lb
(d, f)	(d, f)	26 L x 10 H x 10 W, 45 lb
(d, f)	(d, f)	26 L x 10 H x 10 W, 45 lb
(d, f)	(d, f)	26 L x 10 H x 10 W, 45 lb
(e, f)	(e, f)	26 L x 10 H x 10 W, 45 lb
1/2" SAE(f)	1/2" SAE(f)	33 L x 10 H x 10 W, 55 lb
(d, f)	(d, f)	33 L x 10 H x 10 W, 52 lb
(d, f)	(d, f)	33 L x 10 H x 10 W, 52 lb
(d, f)	(d, f)	33 L x 10 H x 10 W, 52 lb
(e, f)	(e, f)	33 L x 10 H x 10 W, 52 lb
1/2" SAE	1/2" SAE	18 L x 10 H x 10 W, 30 lb
(d)	1/2" SAE	26 L x 10 H x 10 W, 46 lb
(d)	1/2" SAE	26 L x 10 H x 10 W, 45 lb
(d)	1/2" SAE	26 L x 10 H x 10 W, 45 lb
(d)	(d)	26 L x 10 H x 10 W, 45 lb
(d)	(d)	26 L x 10 H x 10 W, 45 lb
(e)	(d)	26 L x 10 H x 10 W, 45 lb
(d)	(d)	26 L x 10 H x 10 W, 45 lb
(e)	(d)	26 L x 10 H x 10 W, 45 lb
(e)	(d)	26 L x 10 H x 10 W, 45 lb
(e)	(d)	26 L x 10 H x 10 W, 45 lb
(d)	1/2" SAE	33 L x 10 H x 10 W, 53 lb
(d)	1/2" SAE	33 L x 10 H x 10 W, 53 lb
(d)	(d)	33 L x 10 H x 10 W, 53 lb
(d)	(d)	33 L x 10 H x 10 W, 53 lb
(e)	(d)	33 L x 10 H x 10 W, 53 lb
(d)	(d)	33 L x 10 H x 10 W, 53 lb
(e)	(d)	33 L x 10 H x 10 W, 53 lb

Model Designation System

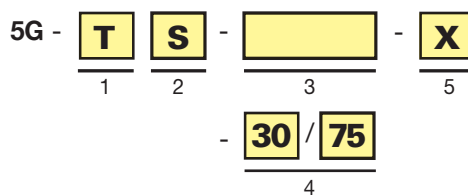

EXAMPLE: 5G-TS-30/75-X

Two Stage, Single Drive
Nominal Area Ratios 30:1 and 75:1
External Pilot Modification

BOX 1: Gas Booster Type

S - Single Acting
D - Double Acting
T - Two Stage

BOX 2: Air Drive Option

S - Single Drive Section
D - Double Drive Section

BOX 3: Ratio—Single Stage Boosters Only

Nominal Ratio of Air Drive Piston(s) Area vs. Gas Piston(s) Area

BOX 4: Ratio—Two Stage Boosters Only

Nominal First Stage Area Ratio/Second Stage Area Ratio

BOX 5: Modifications (See Page 15)

N - Lapped Cycling Valve Assembly
O - Oxygen Gas Service to 5,000 PSI
V - Viton Seals in the Air Drive Section
X - External Pilot Port on Air Drive Section



Multistage system package for boosting argon to 15,000 PSI from a liquid argon vaporizer.

TABLE 1 NOTES

(a) Maximum *safe pressure*, (Page 6) is based on a minimum 4:1 safety factor of the ultimate strength of the hardware exposed to this pressure. But this safe pressure could be exceeded due to external sources, such as thermal expansion or the use of other inlet boosters or compressors, or due to the action of the booster itself (e.g., high inlet pressure or high drive pressure). In these cases, safety relief valve or rupture disk protection must be provided.

(b) On **TWO STAGE MODELS** (Page 6, Items 20-36) the maximum allowable *interstage* pressure during the interstage stroke will be the same as the maximum safe inlet pressure. To determine *potential* maximum interstage pressure and whether an interstage relief valve would be needed:

First, find the model's net ratio in Table 2. (Net ratio is the air drive area vs. the first stage piston area minus the second stage piston area.)

Second, use the air drive PSI and net ratio to calculate maximum potential interstage pressure

$$\text{Maximum potential interstage pressure} = \text{Air Drive PSI} \times \text{Net Ratio}$$

Finally, compare maximum potential interstage pressure to maximum safe inlet pressure. If the former exceeds the latter, an interstage relief valve is needed.

Examples using 100 PSI air drive: Model 5G-TS-7/14 does not need an interstage relief valve because maximum potential interstage pressure of 1,400 (100 x 14) is less than maximum safe inlet pressure of 2,500. With Model 5G-TD-28/60, an interstage relief valve set at 4,500 PSI is needed because maximum potential interstage pressure of 5,250 (100 x 52.5) exceeds maximum safe inlet pressure of 4,500.

(c) *Interstage stall* on two stage models (Items 20-36, Page 6). The swept volume of the first stage is always larger than that of the second stage. To complete its interstage stroke, the first stage must compress and move its gas volume into the second stage. The amount of compression will be the assist factor x the inlet PSI. But the drive may not be able to do this because its force is limited by its net ratio and it may stall (on the interstage stroke only). (See Table 2 for assist factors.)

Example using 100 PSI air drive and Model 5G-TS-14/30: Per Note (b) equation, maximum potential interstage pressure is 2,625 PSI; this is the maximum PSI the model can generate in its first stage. So if inlet gas is at 1,200 PSI (and system outlet gas exceeds 2,625 PSI), the unit will *almost* stall as it compresses its 1,200 PSI inlet gas (by assist factor 2.14 to 2,568 PSI) into the second stage. If inlet gas is 1,300 PSI, the unit *will* stall (because 1,300 x 2.14 = 2,782 PSI, which exceeds maximum potential interstage pressure).

Interstage stall poses no harm to the gas booster and no safety hazard. To release the stall and allow the booster to cycle normally, simply throttle the inlet gas line. This maneuver reduces the gas incoming volume and pressure enough to prevent stall. Eventually, the gas supply cylinder(s) in this example will deplete below 1,226 PSI, making interstage stall impossible (2,625 maximum potential interstage pressure/2.14 = 1,226.6).

(d) *Combination port*: This port will accept either:

- a 3/8" SAE tube fitting or adapter with O-ring or
- a 1/4" super pressure fitting with heavy wall, threaded and coned, 1/4" O.D. x .083 wall, S.S. tube (as illustrated).

Correct selection for gas service:

SAE O-ring boss fittings: up to 6,000 PSI; and 1/4" super pressure tube and fitting: 6,000 thru 25,000 PSI.

(e) *1/4" Super pressure only*. This port will only accept a 1/4" super pressure fitting with heavy wall, threaded and coned 1/4" O.D. tubing.

(f) *Double acting models* include high pressure stainless steel tubing and fittings. Common tees connect the tubing and fittings to the outlet and inlet ports; see Table 3 for details and Table 1, Items 10-19, Page 6 for schematic symbols. Using this tubing, maximum safe pressures are the same as shown in Table 1 except as noted beneath Table 3.

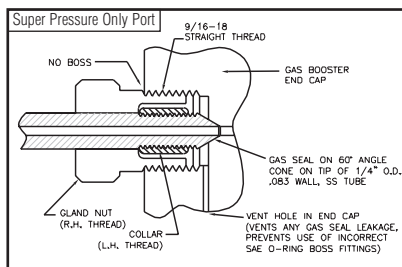
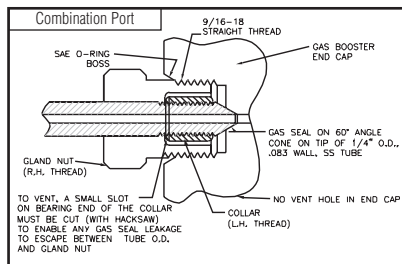

Figure 2. Combination Port and Super Pressure Only Port

Table 2. Net Ratios and Assist Factor of Two Stage Models

Model No.	Net Ratio	Assist Factor
		First Stage to Second Compression
5G-TS-7/14	14:1	2:1
5G-TS-7/30	9.13:1	4.29:1
5G-TS-7/50	8.14	7.14
5G-TS-14/30	26.25:1	2.14:1
5G-TS-14/50	19.44:1	3.57:1
5G-TS-14/75	17.2:1	5.36:1
5G-TS-30/50	75:1	1.66:1
5G-TS-30/75	50:1	2.5:1
5G-TS-30/92	44.52:1	3.06:1
5G-TS-50/92	109.5:1	1.84:1
5G-TD-14/28	28:1	2:1
5G-TD-14/60	18.26:1	4.28:1
5G-TD-28/60	52.5:1	2.14:1
5G-TD-28/100	38.89:1	3.57:1
5G-TD-28/150	34.4:1	5.36:1
5G-TD-60/100	150:1	1.66:1
5G-TD-60/150	100:1	2.5:1

Table 3. Data on Standard Tee Connections and Tubing Included on Double Acting Models

Model No.	User Connection at Tee	
	Outlet	Inlet
5G-DS-7	37° Flare 1/2"	37° Flare 1/2"
5G-DS-14	37° Flare 1/4"	37° Flare 3/8"
(f) 5G-DS-30	37° Flare 1/4"	37° Flare 3/8"
(f) 5G-DS-50	37° Flare 1/4"	37° Flare 3/8"
5G-DS-75	Super Pr. 1/4"	Super Pr. 1/4"
5G-DD-14	37° Flare 1/2"	37° Flare 1/2"
5G-DD-28	37° Flare 1/4"	37° Flare 3/8"
(f) 5G-DD-60	37° Flare 1/4"	37° Flare 3/8"
(f) 5G-DD-100	37° Flare 1/4"	Super Pr. 1/4"
5G-DD-150	Super Pr. 1/4"	Super Pr. 1/4"

(f) **Maximum Safe PSI with Tubing.**

5G-DS-30, DS-50, DD-60: Inlet 6,500, Outlet 7,500

5G-DD-100: Inlet 6,500, Outlet 15,000

Table 4. Selected SAE Port and Fitting Detail

SAE Boss	Dash No.	Boss o-ring, in.		Thread, inches Boss or 37° Flare Male
		I.D.	Wall	
1/4" Tube	-4	.351	.072	7/16-20
3/8" Tube	-6	.468	.078	9/16-18
1/2" Tube	-8	.644	.087	3/4-16
5/8" Tube	-10	.755	.097	7/8-14
3/4" Tube	-12	.924	.116	1 1/16-12

HOW TO USE THE PERFORMANCE CURVES

SINGLE UNIT

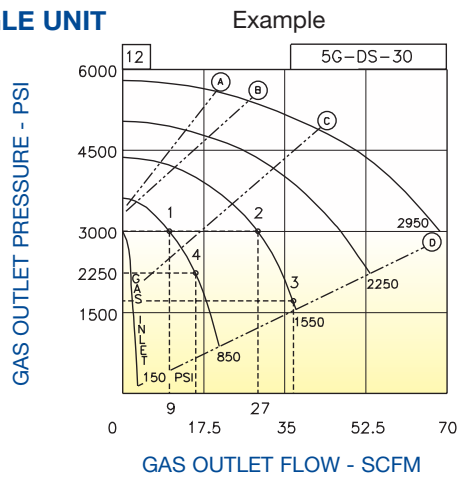

reason for this significant increase in outlet flow is twofold: First, about twice as much gas is inhaled with each cycle; and second, the cycling speed increases as the load on the drive decreases. (850 PSI inlet to 3,000 PSI outlet = 2,150 PSI load; 1,550 PSI inlet to 3,000 PSI outlet = 1,450 PSI load.) Note: On single acting models (Line Items 1-8 of Table 1 on Page 6), the load is not reduced as gas inlet pressure increases. But the volume of gas inhaled with each cycle does increase in direct proportion to the inlet gas pressure.

Use the curves on Pages 10-12 for rough estimates only; gas booster applications that have constant gas inlet and outlet pressures are rare. Examples 1 and 2 on Page 4 represent more common situations. In Example 1, pressure is equalized across the booster so that inlet and outlet pressures are the same. Then as the booster cycles, inlet pressure continually decreases while outlet pressure continually increases. The momentary outlet flow at a fixed inlet-outlet pressure combination is not important to prospective users—but the average of a number of outlet flow values at a spread of inlet-outlet pressures is. See performance curves (on left) for Model 5G-DS-30. If the equalized inlet and outlet pressure is 1,550 PSI, outlet flow will be about 36 SCFM (Point 3) when the booster starts. Then inlet pressure decays to 850 PSI and outlet pressure increases to 2,250 PSI; outlet flow will be about 16 SCFM at this point (Point 4). During that boost, average outlet flow is about 26 SCFM $[(36+16)/2]$. If the gas receiver or test object requires about 100 SCF to raise its pressure from 1,550 PSI start to 2,250 PSI finish, the time to achieve this can be roughly predicted as about 4 minutes (100 SCF/26 SCFM). For more precise time estimates, plot more points for a broader average.

The performance curves are used to estimate flow capacities and receiver fill times. **The performance curves demonstrate that gas inlet pressure is the primary factor affecting the outlet flow capacity of all gas boosters.**

Example: If inlet supply pressure is 850 PSI, outlet flow at 3,000 PSI is about 9 SCFM maximum (Point 1). If inlet supply pressure is increased to 1,550 PSI, outlet flow at 3,000 PSI triples to 27 SCFM maximum (Point 2). The

Estimating the time required to reach maximum pressure is easier if gas inlet pressure is constant as in Examples 3 and 4 on Page 5.

MULTIPLE BOOSTERS PIPED IN SERIES³ (See Example 4, Page 5)

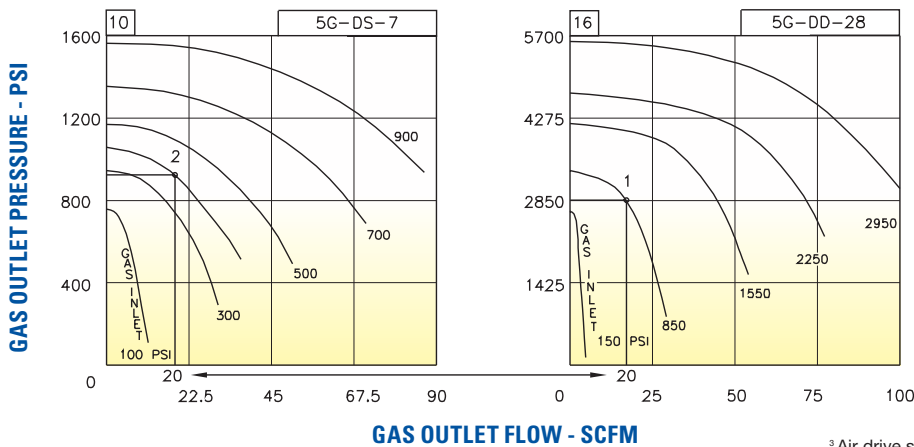

As described above, the higher the gas inlet pressure, the higher the outlet flow capability. If the model selected can reach the final outlet pressure needed, but is short on outlet flow at that pressure, piping two gas boosters in a series is the solution. In this case, the “pre-booster” provides more-or-less constant elevated gas-inlet pressure to the “final” booster. Example: See curves above. Model 5G-DS-7 curves show it can provide 20 SCFM outlet to the 5G-DD-28 inlet at 850 PSI or more, from a 400 PSI gas inlet source (Point 2). Model 5G-DD-28 will provide about 20 SCFM outlet flow at 2,850 PSI (Point 1) if the gas inlet PSI is held at 850 PSI.

³ Air drive source for staged boosters should be from 3/4" ID piping or larger.

PERFORMANCE CURVES—Assume an air drive source of approximately 95 PSI from 1/2" ID piping.

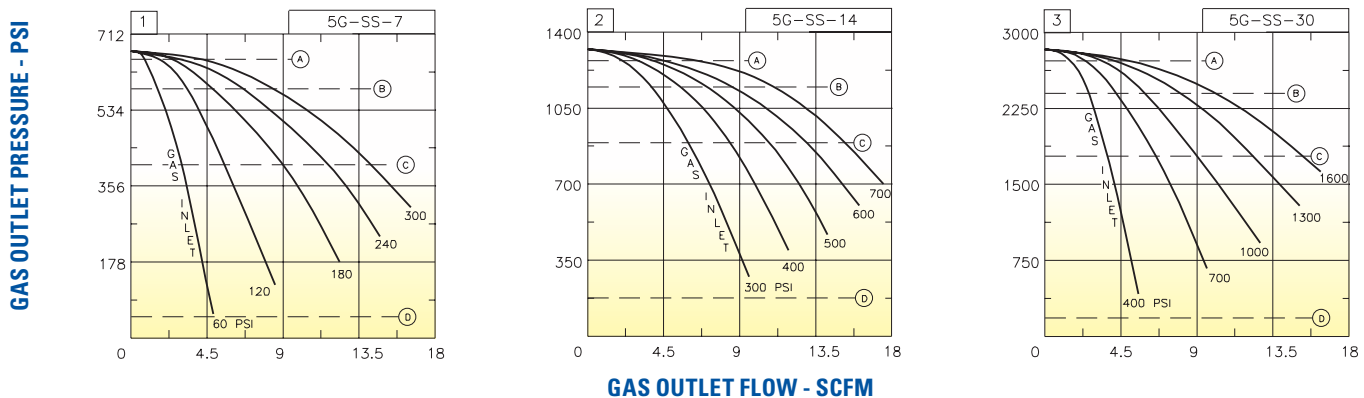

PERFORMANCE CURVES—Assume an air drive source of approximately 95 PSI from 1/2" ID piping.

GAS OUTLET PRESSURE - PSI

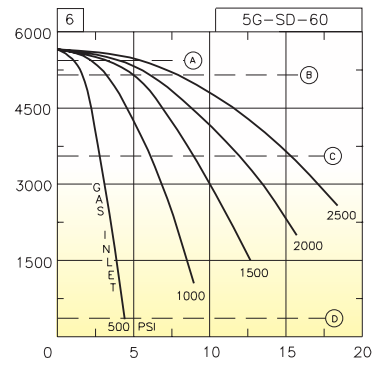
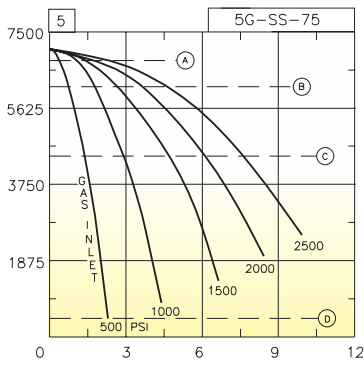
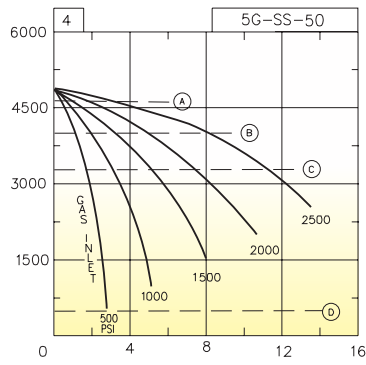

GAS OUTLET FLOW - SCFM

GAS OUTLET PRESSURE - PSI

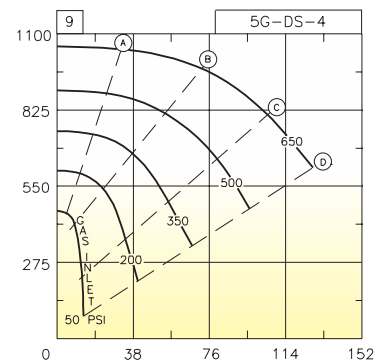
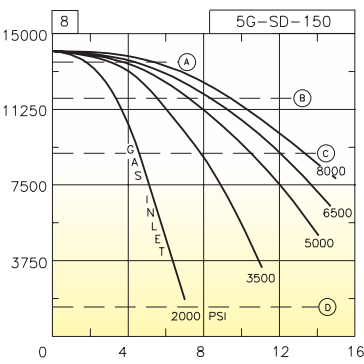
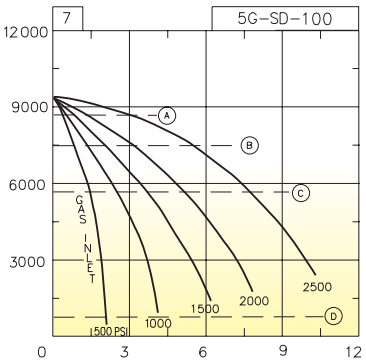

GAS OUTLET FLOW - SCFM

GAS OUTLET PRESSURE - PSI

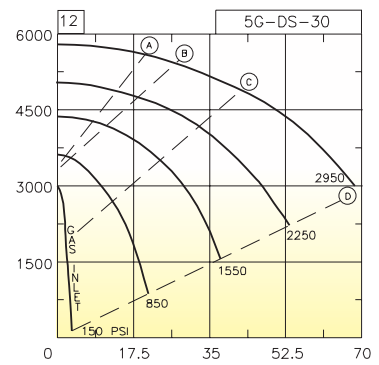
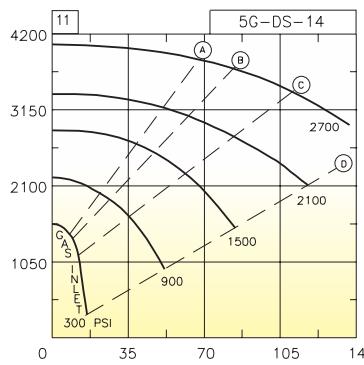
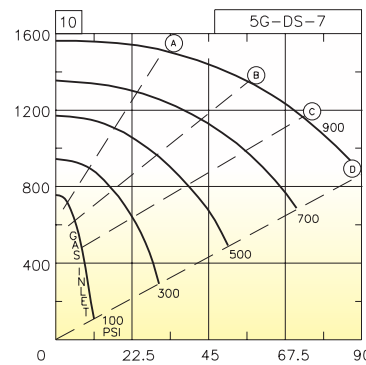

GAS OUTLET FLOW - SCFM

GAS OUTLET PRESSURE - PSI

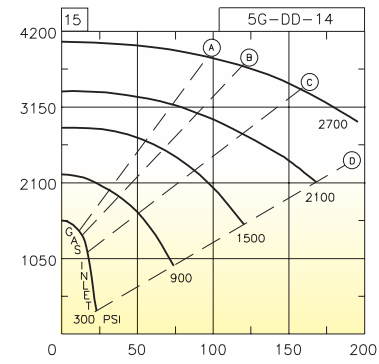
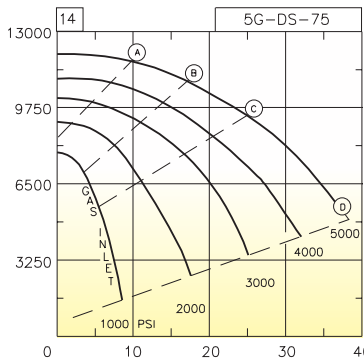
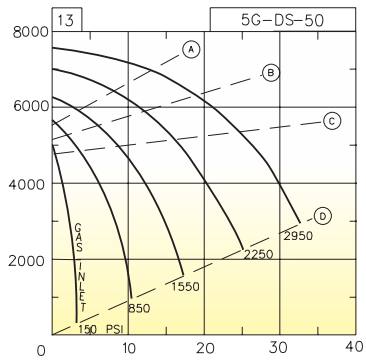

GAS OUTLET FLOW - SCFM

AIR DRIVE FLOW (DOTTED CURVES)

MODEL	A	B	C	D
5G-DS-4	10	20	30	50
5G-SS/DS	15	30	50	75
5G-DD/TD	30	60	90	130

PERFORMANCE CURVES—Assume an air drive source of approximately 95 PSI from 1/2" ID piping.

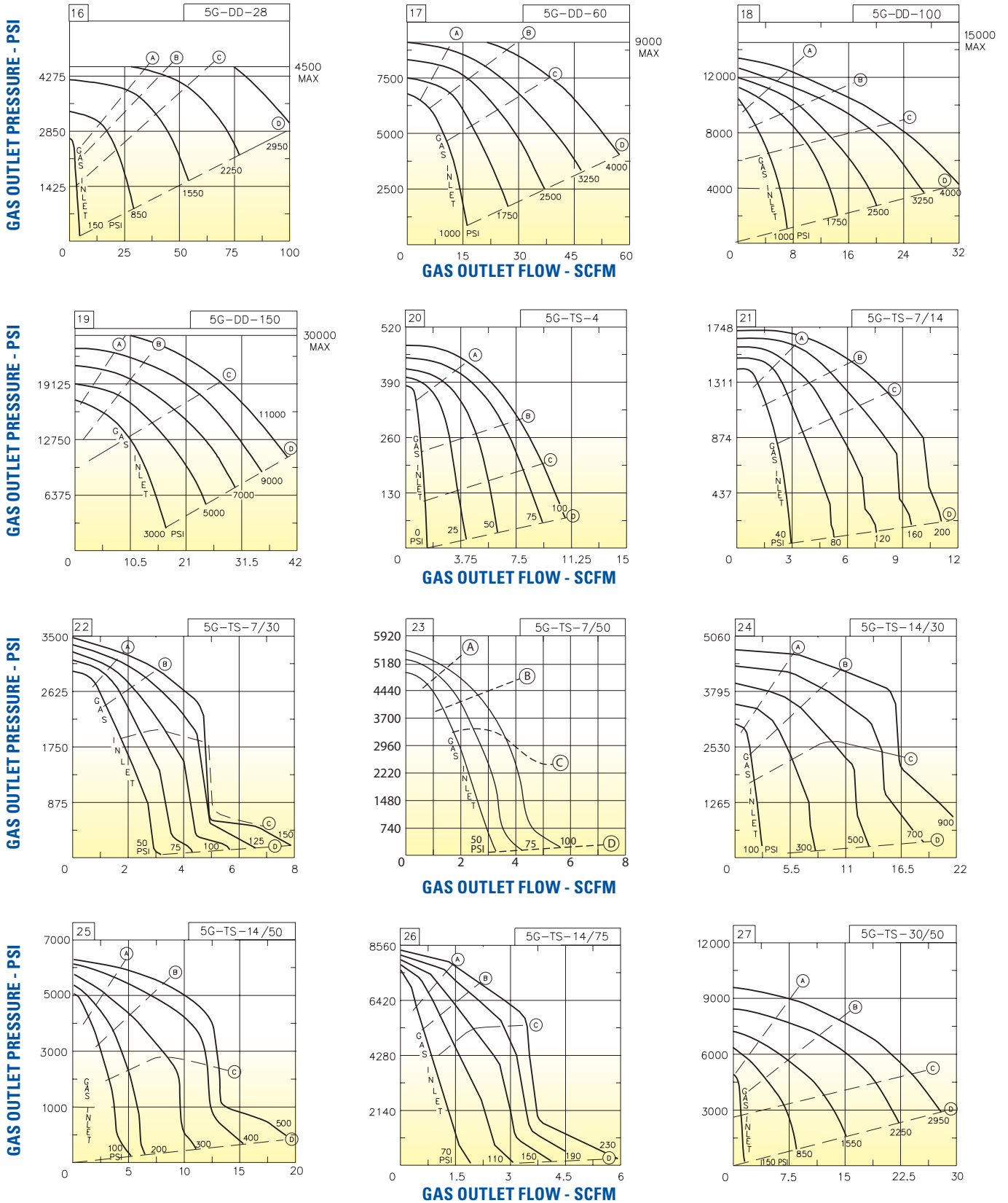

AIR DRIVE FLOW (DOTTED CURVES)

MODEL	A	B	C	D
5G-DS-4	10	20	30	50
5G-SS/DS	15	30	50	75
5G-DD/TD	30	60	90	130

PERFORMANCE CURVES—Assume an air drive source of approximately 95 PSI from 1/2" ID piping.

GAS OUTLET PRESSURE - PSI

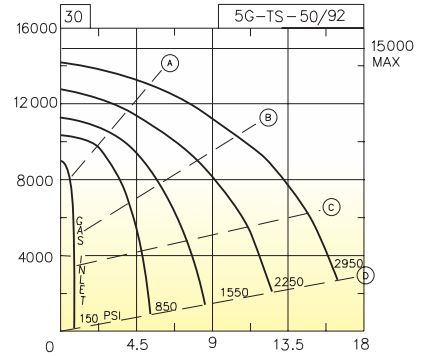
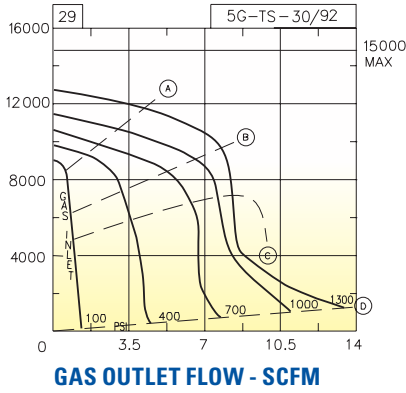
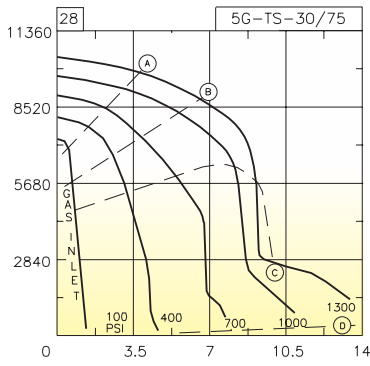

GAS OUTLET FLOW - SCFM

GAS OUTLET PRESSURE - PSI

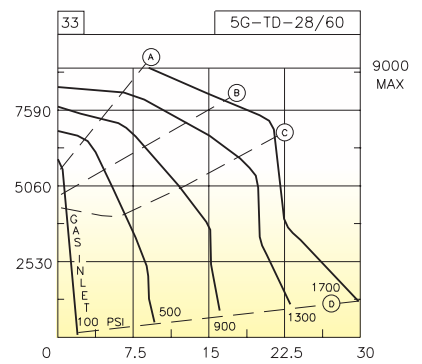
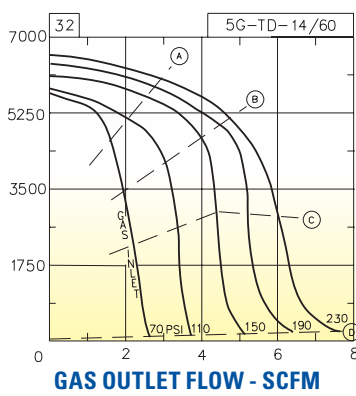
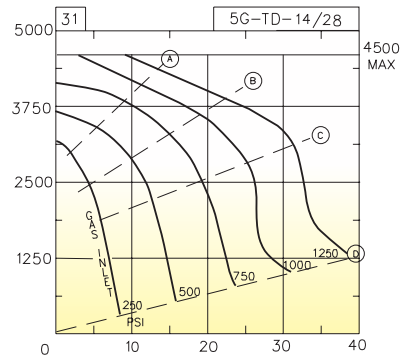

GAS OUTLET FLOW - SCFM

GAS OUTLET PRESSURE - PSI

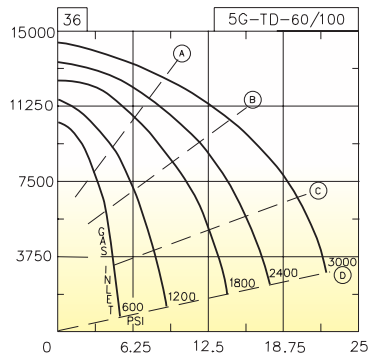
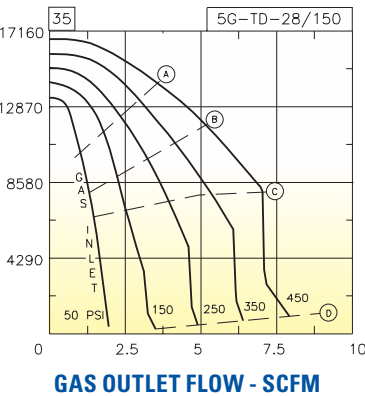
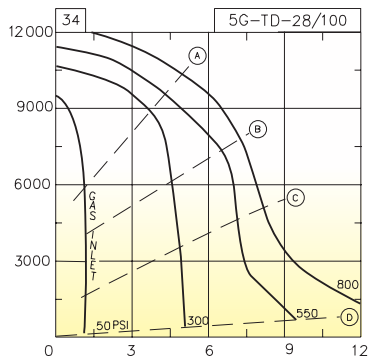

GAS OUTLET FLOW - SCFM

GAS OUTLET PRESSURE - PSI

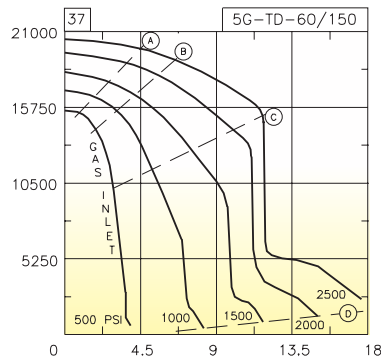

GAS OUTLET FLOW - SCFM

AIR DRIVE FLOW (DOTTED CURVES)

MODEL	A	B	C	D
5G-DS-4	10	20	30	50
5G-SS/DS	15	30	50	75
5G-DD/TD	30	60	90	130

INSTALLATION DETAIL (Refer to Page 6 for item numbers)

DIMENSIONAL DATA

SS SERIES ITEMS 1, 2, 3, 4, 5

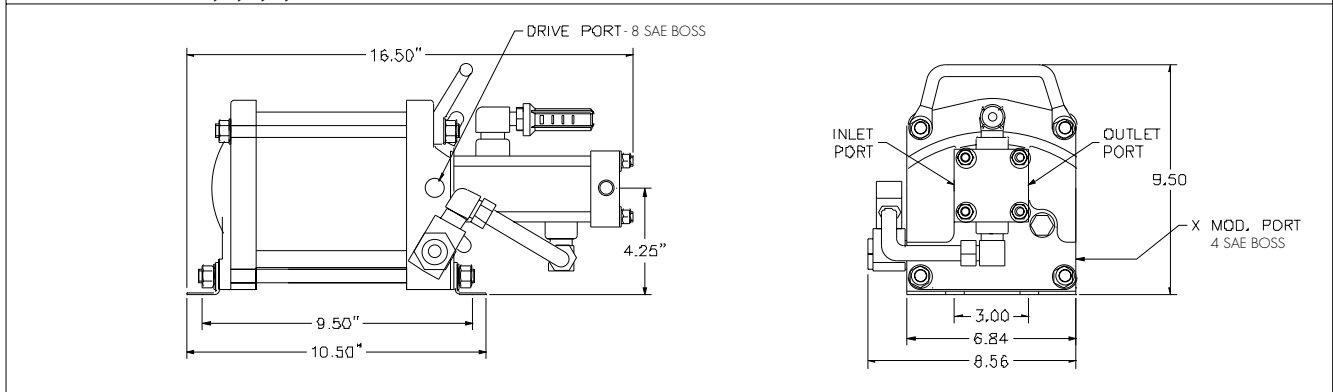

SD SERIES ITEMS 6, 7, 8

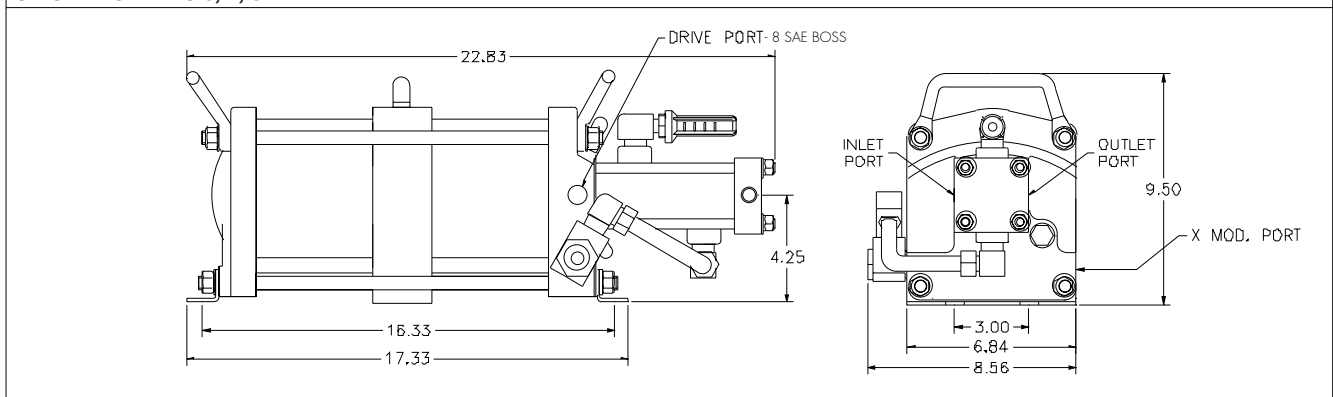

DS SERIES ITEM 9

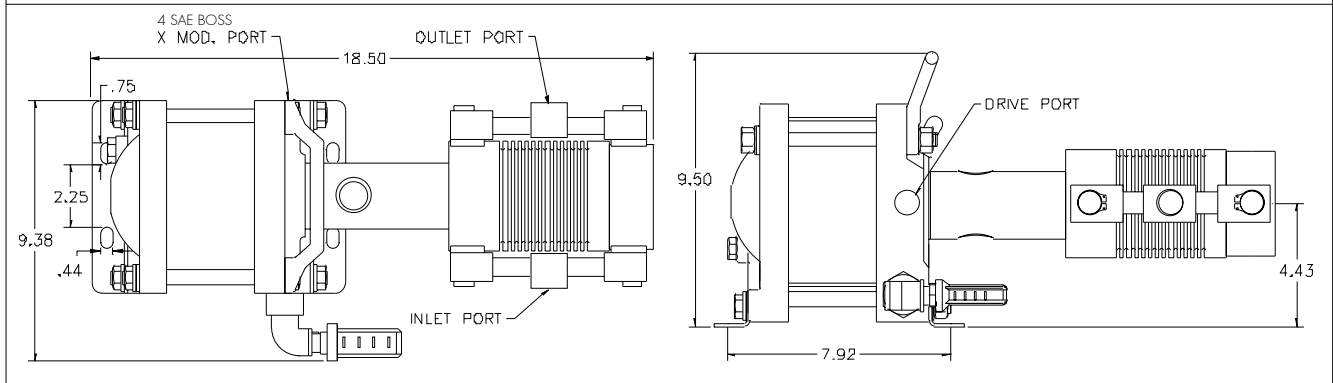

ITEMS 10, 11, 12, 13, 14

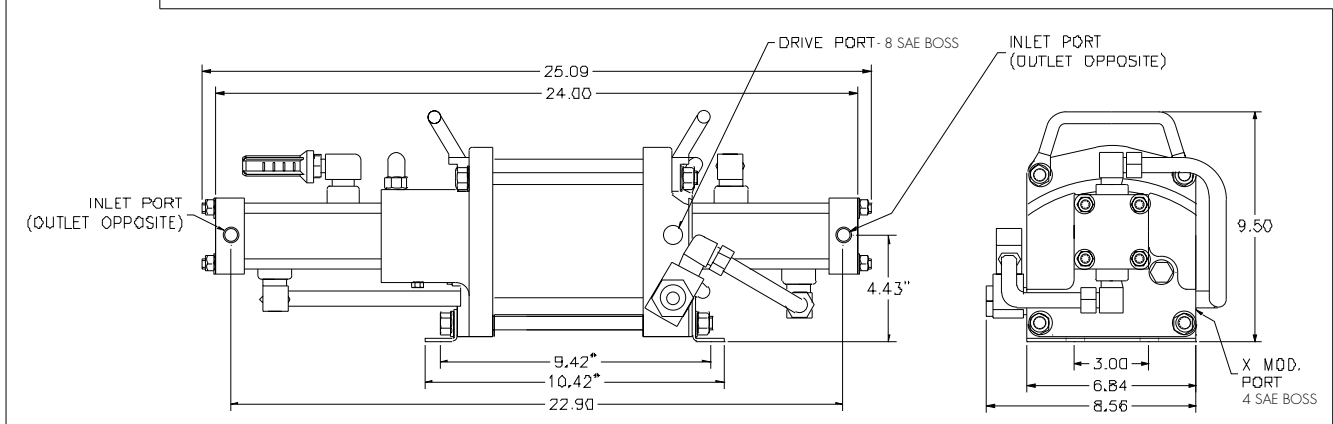

INSTALLATION DETAIL (Refer to Page 6 for item numbers)

DIMENSIONAL DATA

DD SERIES ITEMS 15, 16, 17, 18, 19

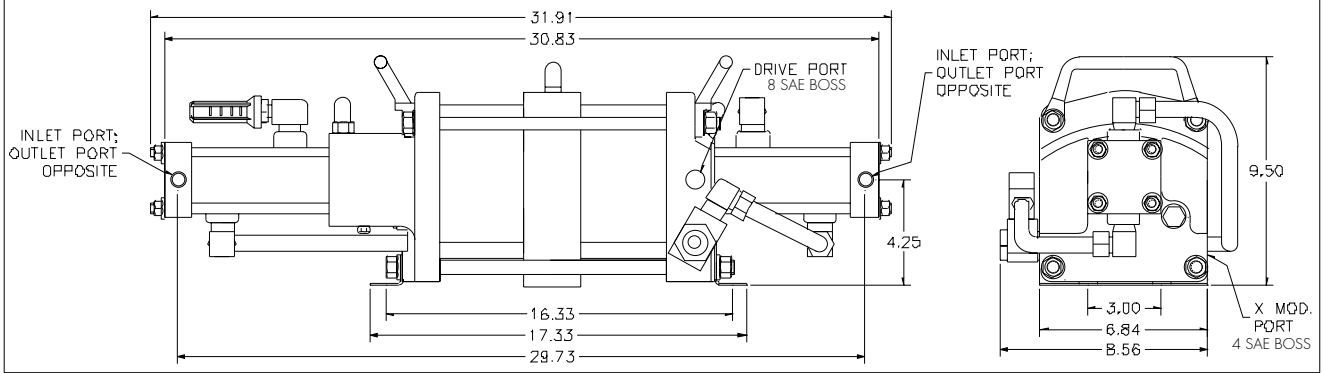

TS SERIES ITEM 20

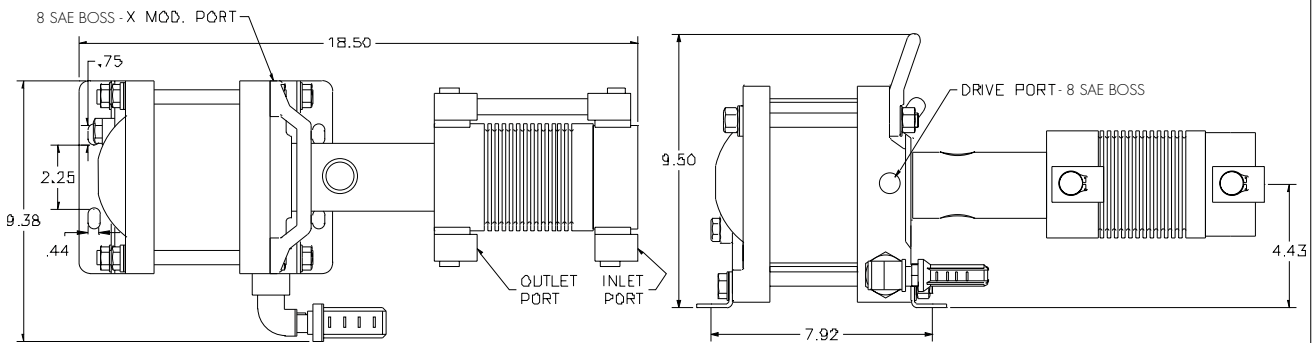

ITEMS 21, 22, 23, 24, 25, 26, 27, 28, 29, 30

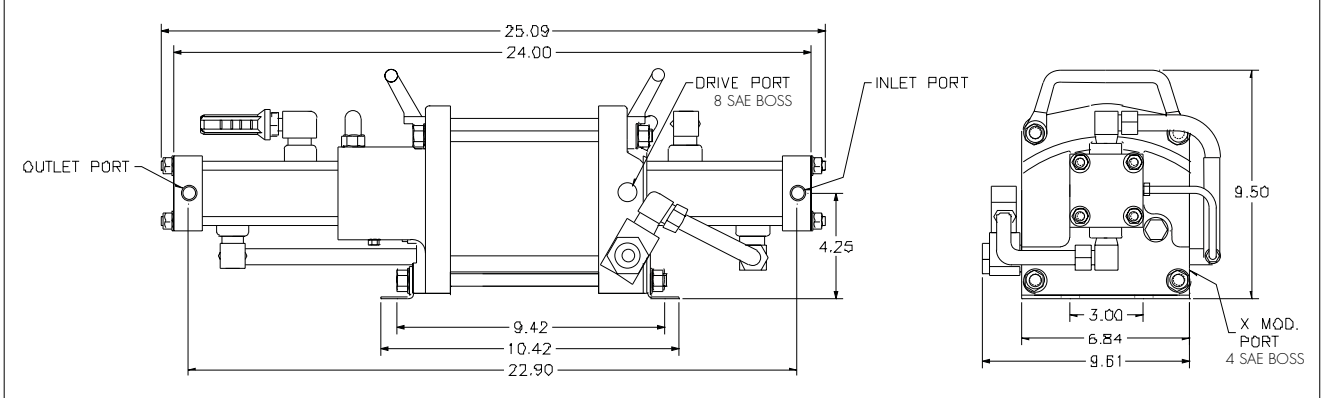

TD SERIES ITEMS 31, 32, 33, 34, 35, 36, 37

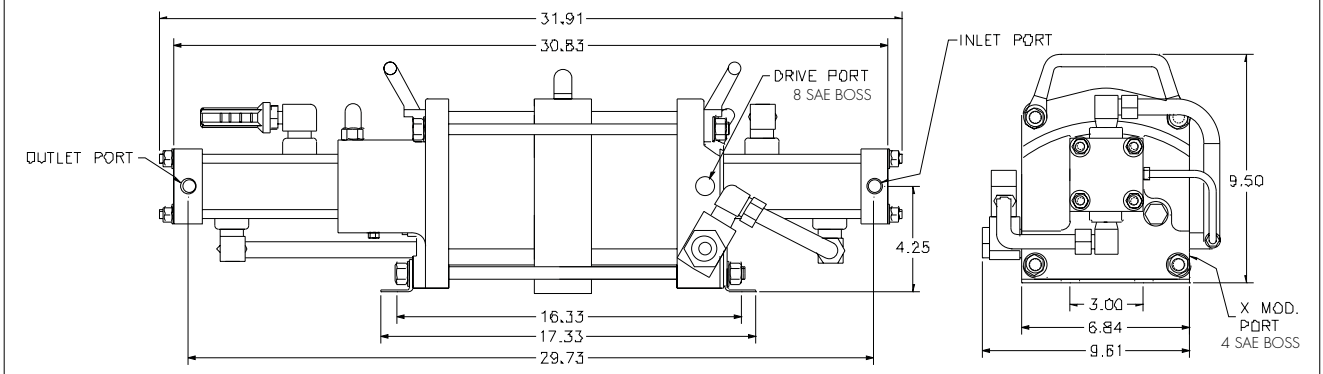

STANDARD MODIFICATIONS

Order any gas booster modification by specifying the modification letter after the model number.

- **“N” Lapped Cycling Valve Assembly** : Designed for continuous duty applications where it is impractical to periodically grease and maintain the standard O-ring sealed spool. It should also be considered where the drive air or gas contains vapors that may swell rubber O-rings, or where the drive is extremely wet or extremely dry making O-ring grease difficult to maintain. This assembly consists of a lapped, match fit, spool and sleeve.
- **“O” Oxygen Gas Service to 5,000 PSI**: Before gas booster shipment, HII verifies suitability for pure O₂ using special high-pressure O₂ test. Labels attached to gas booster note oxygen rating and maximum pressure. Not available for -4 models.

Warning: To avoid accidental contamination, mount gas booster horizontally and do not use gases other than oxygen.

- **“V” Viton Sealed Drive Section**: HII replaces all Buna static and dynamic seals in the drive section of the gas booster. This modification provides chemical resistance if drive air or gas has entrained substances incompatible with Buna. Examples of Buna-incompatible substances include hydrogen sulfide and some synthetic lubricants used in shop air compressors.
- **“X” External Pilot Port on Air Drive Section**: Enables start/stop control of the air drive using a small shutoff valve provided by end user. Connection is 1/4” SAE Boss. A simple kit is also available for conversion to external air pilot in the field.

HYDRAULICS INTERNATIONAL, INC. OVERVIEW

Founded in 1976, HII has evolved into a fully integrated manufacturer of hydraulic and pneumatic test equipment. HII maintains four modern facilities; three in Chatsworth, California and one in Forsyth, Georgia, totaling 690,000 square feet.

Along with air driven liquid pumps, HII offers air driven gas boosters, air pressure amplifiers, flowmeters, sophisticated custom systems and components. HII products are designed and manufactured in the USA.

■ ISO 9001: 2008 & AS9100-2009 Certified Quality System



CORPORATE HEADQUARTERS AND OFFICES, SALES, ADMINISTRATION, FABRICATION AND ASSEMBLY



ENGINEERING, ASSEMBLY AND TEST FACILITY



MACHINE SHOP FACILITY



AIRCRAFT COMPONENTS AND GSE MRO FACILITY

OTHER HII QUALITY PRODUCTS

AIR DRIVEN LIQUID PUMPS

- Self lubricating
- No electrical power needed
- Portable, lightweight and economical
- Wide range of models in 3", 5 3/4" and 7" drive sizes
- Pressures up to 80,000 PSI (5517 BAR)
- All models are rated for plain water or oil
- Ideal for OEM applications



ELECTRIC DRIVEN GAS BOOSTERS

- Boosts pressure from 50 PSI (3.4 BAR) to 10,000 PSI (689 BAR)
- Two-man portable
- Uses no belts or pulleys
- Quiet, only 65 dBA
- Offered in double acting and 2-stage configuration



AIR DRIVEN AIR PRESSURE AMPLIFIERS

- Boosting shop air to pneumatic tools, cylinders and devices
- Boosting shop air to drive high-pressure pneumatic diaphragm transfer pumps
- Boosting shop air to start oilfield and marine diesel engines
- Maximizing efficiency at pneumatic workstations or machinery
- Tire pressure top off on large mining vehicles
- Replace bottled nitrogen for gas testing, lab or production, up to 700 psi (48.3 BAR)

FLOWMETRICS

- Liquid Flowmeters - to 15,000 GPM (56,781 lit/min)
- Gas Flowmeters - to 15,000 CFM (425 Nm³/min)



COMPONENTS

- Check valves - up to 20,000 PSI (1379 BAR), up to 2"
- Needle valves - straight or angled to 5,000 PSI (345 BAR)
- In-line filters rated to 5,000 PSI (345 BAR), 3 to 25 micron
- Double acting hand pumps - to 3,000 PSI (207 BAR)
- Pressure relief valves - to 60,000 PSI (4137 BAR)

SYSTEMS

- Aircraft Ground Support Equipment (portable & stationary)
- Component Test Equipment
- Customer Designed Equipment
- Central Systems
- Commercial and Military Applications
- Self Propelled Aerial Lift Truck



Our products are designed,
sourced and manufactured
in the U.S.A.



InstruMetrics
ENGINEERING

HYDRAULICS INTERNATIONAL, INC.

9201 Independence Avenue, Chatsworth, CA 91311 USA

Tel: (818) 407-3400 • Fax: (818) 407-3428 • Email: sales@hiipumps.com

hiigroup.com