

ADTS 542F/552F/553F/554F

Air Data Test Set
Safety and Installation Guide



InstruMetrics
ENGINEERING

1. Introduction

This manual is applicable to ADTS542F/552F/553F and 554F, referred to as ADTS, and provides safety and installation information for the Air Data Test Set, compatible with the requirements of first line operation.

A touchscreen (ADTS Touch) is used to control all required functions. The ADTS Touch can be positioned on the ADTS or used as a hand held mobile unit via a cable or Bluetooth® wireless technology. This allows a person to complete the entire test program remotely while conveniently seated in the aircraft. An ADTS Touch-ER option can be purchased for robust wireless communications in a large body aircraft. The ADTS Touch can be powered when positioned on the ADTS, or using a cable connection to the ADTS or battery powered.







The manufacturer has designed this equipment to be safe when operated using the procedures detailed in this manual.

For details of calibration requirements for the ADTS, refer to User Manual K0553.

For details of available manufacturer specified parts, refer to the current revision of the product data sheet.

Service/maintenance and repair will be carried out at Druck authorized service centers.

1.1 Markings and Symbols

| Symbol | Description |
|---|--|
|  | This equipment meets the requirements of all relevant European safety directives. The equipment carries the CE mark. |
|  | This symbol, on the equipment, indicates that the user should read the user manual. |
|  | This symbol, on the equipment, indicates a warning and that the user should refer to the user manual. |
|  | This symbol warns the user of the danger of electric shock. |
|  | Do not dispose of this product as household waste. Use an approved organization that collects and/or recycles waste electrical and electronic equipment. For more information, contact our customer service department, or your local government office. |
|  | The Bluetooth® wireless technology word mark and logos are registered trademarks owned by Bluetooth SIG, Inc. and any use of such marks by Druck is under license. Other trademarks and trade names are those of their respective owners. |

For the list of Druck approved service centers, go to:

Druck.com

1.2 Intended Use

Test and calibration of aircraft aeronautical pressure instruments located indoor in a hanger or calibration laboratory or outdoor (non-continuously) on a runway, refer to User Manual K0553 for further information.



WARNING This equipment is not rated for use in potentially explosive atmospheres. Using this equipment in a potentially explosive atmosphere could lead to serious injury or death.

If the equipment is used in a manner not specified by this document and K0553 the protection provided by the equipment may be impaired.

1.3 Safety

Examine all equipment to be used, paying particular attention to electrical leads and connectors and pneumatic pipes and connectors. DO NOT use any equipment that is known to be or suspected to be damaged or faulty.

1.4 Power Supply

| | | |
|--------------|--|--------------------------------|
| Single phase | 110/230 Vac, 50/60Hz 115 Vac, 400Hz | 200 VA Max - ADTS542F/ADTS552F |
| | | 300 VA Max - ADTS553F/ADTS554F |

1.5 Power Supply Connection

Do not apply electrical power outside the values stated.

Make sure that the power supply is off before connecting the power cable.

The ADTS must be connected to the correct electrical power supply as stated, adjacent to the power connector.



RISK OF ELECTRIC SHOCK There is a risk of electric shock/electrocution if there is not a protective earth in place. The ADTS must, at all times, be connected to the supply protective earth/ground.

The power supply cable and connector must be correctly rated for the power supply. Only use power cables supplied by Druck specifically for the ADTS.

| European Color | US Color | Function |
|----------------|----------|---------------------------|
| Brown | Black | Live |
| Blue | White | Neutral |
| Green/Yellow | Green | Protective Earth (Ground) |

1.6 Fuses

The two High Breaking Capacity fuses (8) (see Figure 6), located in the holders and mounted on the front panel, protect the unit. The fuses are connected in the live and neutral supply circuit and are rated at: T5AH 250V.

1.7 Replacing a Fuse

1. Disconnect the electrical power supply.
2. Unscrew the fuse holder cap from the front panel and remove the fuse.
3. Fit a new fuse of the correct size and rating into the fuse holder cap.
4. Secure the fuse holder cap in the front panel.

2. ADTS Touch

The ADTS Touch is used to control all required functions. The ADTS Touch can be positioned on the ADTS or used as a hand held mobile unit via a cable or Bluetooth® wireless technology.

The ADTS Touch will have power applied when:

- Positioned (docked) (1) on a powered-on ADTS.
- Using an umbilical cable connected to a powered-on ADTS.
- Powered from its own battery pack.
- Powered from a universal power supply unit

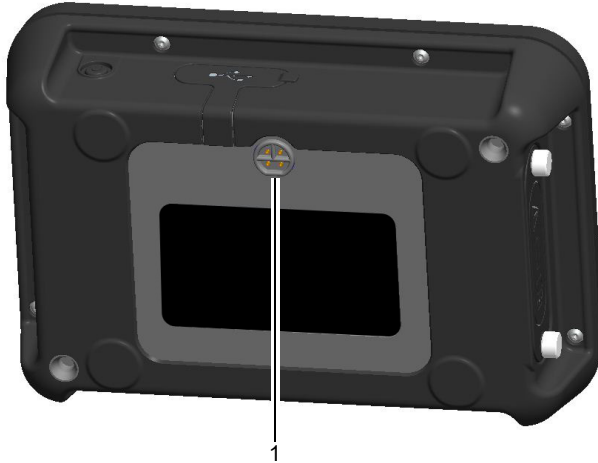

Figure 1: ADTS Touch Docking Connector

The ADTS Touch is equipped with an On/Off switch (2) and USB connectors for connection to a PC or mass storage device (3).

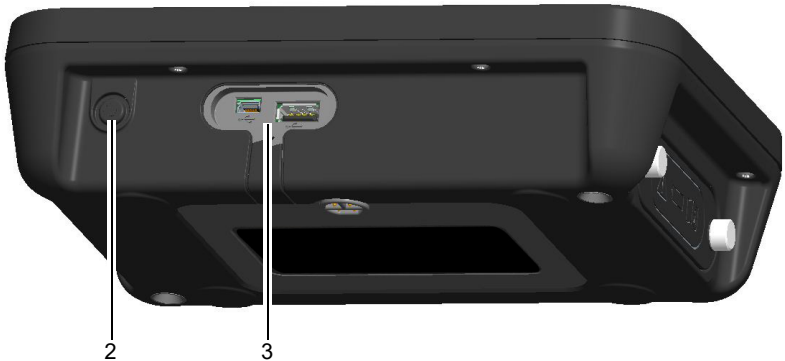

Figure 2: Touch On/Off Switch and USB Connectors

Connector (4) allows connection between the base unit and the ADTS Touch using a 5 metre or 18 metre umbilical cable.

Note: Only use cables that have been supplied by or purchased from Druck.

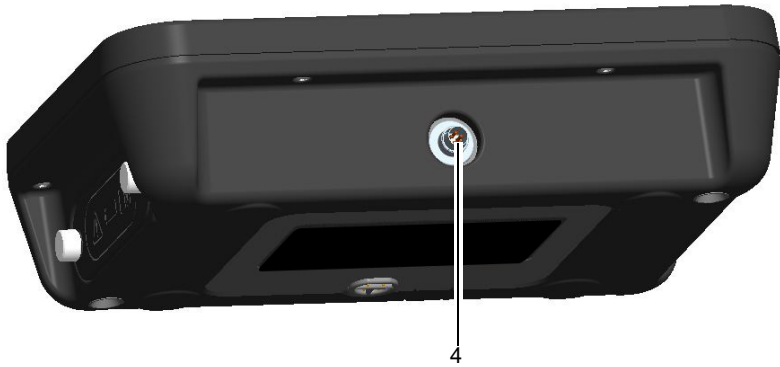

Figure 3: ADTS Touch Umbilical Cable Connector

The ADTS Touch can contain one Lithium-ion battery which is housed in the battery compartment of the ADTS Touch.

2.1 Replacing the Battery



Figure 4: ADTS Touch Battery Compartment

Note: Only use batteries that have been supplied by or purchased from Druck.

Prior to replacing the battery, switch the ADTS Touch off. If the ADTS Touch is connected to the umbilical cable or Docking connector, disconnect prior to removing the battery cover plate.

1. Unscrew the two thumbscrews (5) of the battery compartment cover plate and remove the cover plate.



CAUTION When the battery compartment cover plate is removed and the ADTS touch is tilted with the battery compartment facing downwards, the battery can fall out of the ADTS touch causing damage to the battery.

2. Use the tab attached to the battery to slide the battery out of the battery compartment.
3. Fit a new or re-charged battery into the battery compartment, observing the keyed orientation.

Note: The battery does not necessarily need to be new or re-charged. The ADTS Touch will function safely and correctly with a flat battery when the umbilical cable or dock charging supply is connected.

4. Refit the battery compartment cover plate and tighten the two thumbscrews (5). The cover must be fitted correctly to maintain protection afforded.

2.2 Battery Care and Maintenance

The battery unit contains a Lithium-ion battery which requires no user maintenance. If shipping an ADTS Touch and/or battery unit please contact your local service center beforehand for shipping requirements. Battery must be removed from the ADTS Touch during transportation. Prolonged exposure to temperature extremes may significantly reduce battery lifetime. For maximum lifetime, avoid prolonged periods where the battery is exposed to temperatures outside the range -30°C to +45°C.

The recommended storage temperature range is 5°C to 21°C (41°F to 98.8°F).

The battery is removable. The manufacturer makes the following safety recommendations. The user should not:

- Short circuit the battery.
- Immerse the battery in any liquid.
- Disassemble or deform the battery.
- Expose to, or dispose of the battery in a fire.
- Subject the battery to excessive physical shock or vibration outside the specified limits for the ADTS.
- Use a battery that appears to have suffered abuse.
- Charge with an unspecified charger or specified charger that has been modified. This can cause breakdown of the battery or swelling and rupturing.
- Use a battery in an appliance or purpose for which it was not intended.

The battery unit is sealed for life, so leakage of electrolyte is not expected. If leakage of electrolyte from the battery is observed, stop using the battery immediately and avoid contact with the electrolyte. If skin or clothes come into contact with the electrolyte, wash immediately with soap and water. If electrolyte comes into contact with the eyes, wash the eyes thoroughly with water and consult a doctor immediately.

The ADTS5xxF, ADTS Touch and ADTS Touch-ER contain a Lithium-ion coin cell. This coin cell is not user replaceable. Installation and replacement shall only be performed by trained personnel.

Always dispose of batteries safely and in accordance with local instructions.

2.3 Battery Charging

The battery in the ADTS Touch can be charged using one of the following methods:

- By placing the ADTS Touch onto a powered ADTS.
- By connecting the ADTS Touch connector (4) (see Figure 3) to the ADTS using the umbilical cable.
- By using the AATOUCH-5 optional accessory desktop charger. The battery must be removed from ADTS Touch when it is charged by the AATOUCH-5 desktop charger.

- Using a universal power supply unit connected to the ADTS Touch using an adapter:



Figure 5: Universal Power Supply Unit and Adapter

The ADTS Touch universal power supply and the desktop charger are both rated for indoor use only.



3. ADTS5xxF

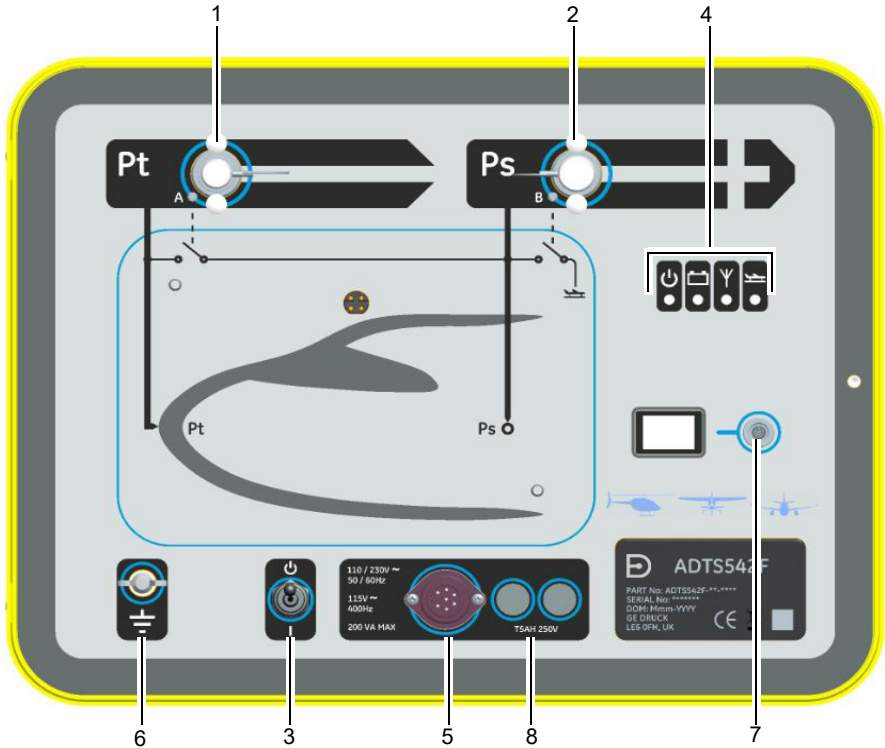

Figure 6: ADTS542F Front Panel

Note: See Figure 8 for other variants.

3.1 Power-Up Test (see Figure 6)

1. Fit “Pitot” (Pt) (1) and “Static” (Ps) (2) port blanks.
2. Ensure that the test set is connected to an external power supply and the supply is switched on.
3. Use the On/Standby Switch (3) on the front of the test set to switch the test set on. The test set performs a self test, resulting in a test set status indication (4a) “Pass” or “Fault”.

The test set status indications are as follows:

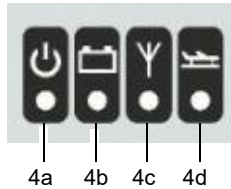

Figure 7: Test Set Status Indications

Test Set Status Indications (4):

Power on and self test:

- Off (Power Off)
- Standby (Yellow)
- 4a • Self test in Progress (flashing Green)
- Pass/Ready (Green)
- Fault (Red)

Battery pack status (if fitted - ADTS542F only):

- 4b • For LED indications, see User Manual K0553 “ADTS542F Battery Pack”

Note: Battery pack is currently not a purchasable option.

Bluetooth® wireless technology connection status:

- Wireless connection present (Blue)
- Wired connection and Bluetooth® option enabled (Flashing blue)
- Fast flash - enabled and visible for pairing (available for 5 minutes after power-up)*
- Slow blink - enabled but not visible for pairing*
- 4c • Bluetooth® option disabled (Wireless LED off)
- Initialization fault (Red) *
- * Only applicable to base unit software variant DK0467

Note: The “fast flash” state also occurs when switching the ON/standby switch from standby to ON. If the Bluetooth® link drops during use then “fast flash” will resume. This occasionally requires the unit to be returned to standby mode before the link can be re-established.

Aircraft status:

- When the ADTS is controlling the aircraft and it is “off ground”, the LED will be Yellow.
- 4d • When the ADTS is controlling the aircraft to “going to ground”, the LED will flash Yellow.
- When the ADTS has made the aircraft “safe at ground”, the LED is Green.
- In standby-mode, this LED will be off.

If the self test fails, or for any other reason the test set is considered to be unserviceable, contact Druck and return the test set to the Druck or Druck approved service center.



WARNING The On/Standby Switch (3) on the front of the test set is not a disconnecting device.

4. To disconnect power to the test set, either:
 - a. Remove the power cable (5) from the front of the test set, or
 - b. Remove the power cable from the wall socket. The wall socket connection must remain accessible.

3.2 External Functional Earth/Ground Terminal

An external earth/ground connection stud (6) is available as a functional earth on the front panel providing a connection/bonding point for other equipment to be connected to the same earth/ground connection as the test set (This is not a protective earth/ground connection).

3.3 Pneumatic Connections

No external pneumatic pressures or vacuums are required as the ADTS contains internal pressure and vacuum pumps.

Hoses (available as orderable accessories on the datasheet) are used for connection to the “Pitot” (Pt) (1) and “Static” (Ps) (2) output ports of the ADTS.

The “Pitot” (Pt) and “Static” (Ps) outputs can then be connected to the corresponding Pitot and Static connectors on the aircraft or aeronautical instruments.

The maximum Pt and Ps output pressure is 2 bar absolute.

The following table details the possible connector specifications:

| Name | Specification |
|------|-------------------------------|
| G1/8 | Pipe Thread ISO 228 - G 1/8 B |
| AN3 | 3/8 - 24 UNJF - 3A Thread |
| AN4 | 7/16 - 20 UNJF - 3A Thread |
| AN6 | 9/16 - 18 UNJF - 3A Thread |

Mating female parts are available from Druck.

3.4 Cleaning



CAUTION Do not use solvents to clean this equipment.

The following materials are approved cleaning agents:

| Material | Specification |
|-----------------|------------------------|
| Lint-free cloth | Commercially available |
| Damp cloth | - |
| Mild detergent | Commercially available |
| Soft brush | Commercially available |

Note: Equivalent alternatives may be used for listed items.

1. Clean the external surfaces of the unit using lint-free cloth and a soft brush. Remove stubborn dirt using a damp cloth and mild detergent and allow to dry.
2. Clean the electrical connector using a soft brush. Remove stubborn dirt using a damp cloth and mild detergent and allow to dry.

4. Specification

4.1 Operating Environment



WARNING This equipment is not rated for use in potentially explosive atmospheres.

| | |
|------------------------------------|--|
| Storage temperatures | ADTS542F: -20°C to 70°C (-4° to 158°F) |
| | ADTS552F) ADTS553F) -20°C to 70°C (-4° to 158°F) ADTS554F) |
| Operating temperatures/environment | ADTS542F: -5°C to 50°C (32° to 122°F) |
| | ADTS552F) ADTS553F) -5°C to 50°C (32° to 122°F) ADTS554F) |
| | Operating humidity: 5% to 95% RH (condensing) |
| | Indoor & Outdoor (non-continuously) use |
| ADTS Touch universal power supply | Operating temperature: 10°C to 50°C (50° to 122°F) |
| | Operating humidity: 5% to 95% RH (non-condensing) |
| Power supply | Universal input Mains Power Supply. |
| | Class 1 equipment requiring a protective earth connection. |
| | TXAH 250V HRC Time-delay (T) 250Va.c. rated fuses (X = amp rating of fuse). |
| | Overvoltage category II, Pollution degree 2 |
| | The supplied mains/PSU cable protective earth/ground conductor must be connected to the power supply protective earth/ground system. |
| Electrical safety | EN 61010-1, UL 61010-1, CSA 22.2, No. 61010-1 and IEC 61010-1 |
| Operating altitude | Maximum 7500ft (2300 metres) |
| Ingress protection | ADTS542/552/553/554 IP33, ADTS Touch IP65 (EN60529) |

4.2 Dimensions



WARNING The ADTS can be moved by use of the handle and wheels. If the ADTS is to be lifted, it must be lifted by at least two people.

| | | |
|------------|--------|--|
| ADTS5xxF | Weight | ADTS542F: 14kg (31lb) (without battery, estimated as 20kg (44lb) with battery) |
| | | ADTS552F: 22kg (48.5lb) ADTS553F: 23.5kg (52lb) ADTS554F: 24.5kg (54lb) |
| | Height | 300mm |
| | Depth | ADTS542F: 320mm (front to rear) ADTS55xF: 425mm (front to rear) |
| | Width | ADTS542F: 420mm (left to right) ADTS55xF: 525mm (left to right) |
| ADTS Touch | Weight | 1kg (2.2lb) |
| | | 1.4kg (3lb) with battery |
| | Height | 58mm |
| | Depth | 154mm |
| | Width | 224mm |

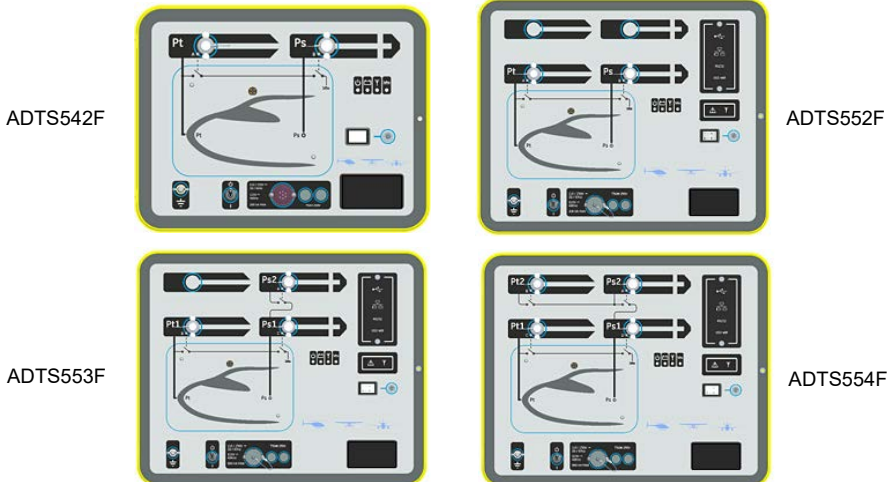

Figure 8: ADTS 5xxF Variants

4.3 Product Labeling

The product label for the base unit can be found in the bottom right hand corner of the front panel. The product label for the ADTS Touch can be found on the rear of the ADTS Touch.

Labeling information consists of:

1. Company logo and product name.
2. Part number
3. Serial number
4. Date of manufacture (DOM).
5. Name and address of manufacturer.

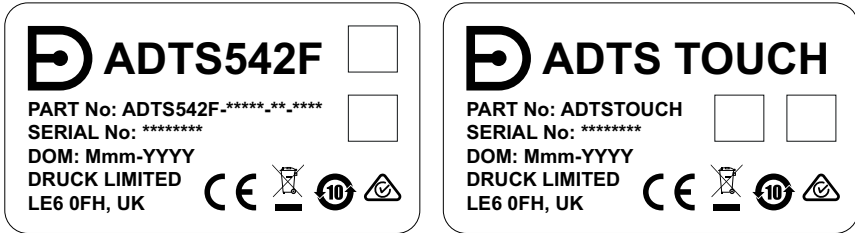

Figure 9: Product Labels



Office Locations

Headquarters

Leicester, UK
☎ +44 (0) 116 2317233
✉ gb.sensing.sales@bakerhughes.com

China

Guangzhou
☎ +86 173 1081 7703
✉ dehou.zhang@bakerhughes.com

Germany

Frankfurt
☎ +49 (0) 69-22222-973
✉ sensing.de.cc@bakerhughes.com

Japan

Tokyo
☎ +81 3 6890 4538
✉ gesitj@bakerhughes.com

UAE

Abu Dhabi
☎ +971 528007351
✉ suhel.aboobacker@bakerhughes.com

Australia

North Sydney
☎ 1300 171 502
✉ custcare.au@bakerhughes.com

China

Shanghai
☎ +86 135 6492 6586
✉ hensen.zhang@bakerhughes.com

India

Bangalore
☎ +91 9986024426
✉ aneesh.madhav@bakerhughes.com

Netherlands

Hoewelaken
☎ +31 334678950
✉ nl.sensing.sales@bakerhughes.com

USA

Boston
☎ 1-800-833-9438
✉ custcareboston@bakerhughes.com

China

Beijing
☎ +86 180 1929 3751
✉ fan.kai@bakerhughes.com

France

Toulouse
☎ +33 562 888 250
✉ sensing.FR.cc@bakerhughes.com

Italy

Milan
☎ +39 02 36 04 28 42
✉ csd.italia@bakerhughes.com

Russia

Moscow
☎ +7 915 3161487
✉ aleksey.khamov@bakerhughes.com

Services and Support Locations

Tech Support

Global
✉ drucktechsupport@bakerhughes.com

France

Toulouse
☎ +33 562 888 250
✉ sensing.FR.cc@bakerhughes.com

UAE

Abu Dhabi
☎ +971 2 4079381
✉ gulfservices@bakerhughes.com

Brazil

Campinas
☎ +55 19 2104 6924, +55 19 97169 1190
✉ cc.sensing.brasil@bakerhughes.com

India

Pune
☎ +91-2135-620421~425
✉ mcindia.inhouseservice@bakerhughes.com

UK

Leicester
☎ +44 (0) 116 2317107
✉ sensing.grobycc@bakerhughes.com

China

Changzhou
☎ +86 400 818 1099
✉ service.mcchina@bakerhughes.com

Japan

Tokyo
☎ +81 3 6894 1838
✉ service.druck.jp@bakerhughes.com

USA

BillERICA
☎ +1 (281) 542-3650
✉ namservice@bakerhughes.com



Copyright 2014 Baker Hughes Company. This material contains one or more registered trademarks of Baker Hughes Company and its subsidiaries in one or more countries. All third-party product and company names are trademarks of their respective holders.

K0554 Revision D | Multilingual

Baker Hughes 

bakerhughes.com